

O-ring Installation Instructions

HOKE Gyrolok O-ring seal fittings are used for direct connection to existing pipe thread or straight thread ports—which have a smooth, flat surface perpendicular to the threaded port. O-ring seal fittings provide leak-tight sealing on both vacuum and high pressure systems. In the pipe thread version, a special short thread insures against thread interference.

The standard Buna N O-ring is completely contained in a precision groove, to prevent O-ring extrusion at high pressure. The precision groove also provides a controlled squeeze for a vacuum-tight seal.

The chart lists pertinent dimensions useful with O-ring seal connectors and adapters.

Note:

When installing an O-ring port:

1. Hand-thread until the O-ring compresses on the port end.
2. Snug the fitting to the port with a wrench to completely compress the O-ring.
3. Always use a back-up wrench to hold the O-ring seal fitting body, when connecting or disconnecting a HOKE Gyrolok end.

To specify O-ring material, see page 6

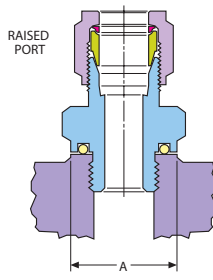

Fig. 1

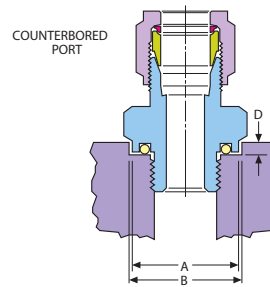

Fig. 2

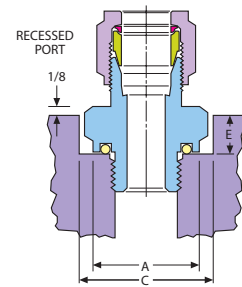

Fig. 3

Mounting Dimensions For O-ring Seal Connectors and Adapters

Straight Thread Size*	Pipe Thread Size**	Diameter		Depth		
		A Min. Flat for Sealing	B Min. for Clearance (Fig. 2)	C Min. for Clearance (Fig. 3)	D Max. (Fig. 2)	E Max. for Adapter (Fig. 3)
5/16-24	—	1/2	9/16	21/32	3/32	3/32
3/8-24	—	17/32	21/32	3/4	3/32	1/8
7/16-20	—	11/16	25/32	7/8	3/32	5/32
1/2-20	—	3/4	29/32	1 1/32	3/32	11/64
9/16-18	—	13/16	31/32	1 3/32	3/32	11/64
3/4-16	—	1	1 5/32	1 5/16	3/32	7/32
7/8-14	—	1 7/32	1 11/32	1 17/32	3/32	5/16
1 1/16-12	—	1 13/32	1 17/32	1 3/4	3/32	11/32
1 5/16-12	—	1 11/16	1 25/32	2 1/32	3/32	7/16
—	1/8 NPT	11/16	25/32	7/8	3/32	9/64
—	1/4 NPT	13/16	31/32	1 3/32	3/32	11/64
—	3/8 NPT	1	1 5/32	1 5/16	3/32	3/16
—	1/2 NPT	1 7/32	1 11/32	1 17/32	3/32	5/16
—	3/4 NPT	1 13/32	1 17/32	1 3/4	3/32	3/8
—	1 NPT	1 11/16	1 25/32	2 1/32	3/32	27/64

Dimensions for reference only, subject to change.

O-ring Straight Connector: COS

connects fractional tube to female straight thread

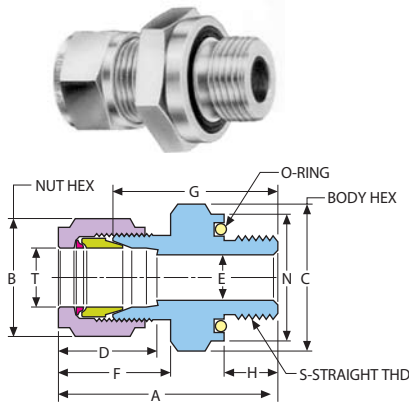

Part Number*	T		S		Dimensions — inches										O-ring	
	Tube O.D.	Thread Size	A	B Hex Flat	C Hex Flat	D	E min	F	G	H	N	I.D.	O.D.			
1COS[]	1/16	5/16-24	1.13	5/16	9/16	.41	.05	.48	.91	.34	.56	.31	.44			
2COS[]	1/8	5/16-24	1.25	7/16	9/16	.56	.09	.67	1.03	.34	.56	.31	.44			
3COS[]	3/16	3/8-24	1.41	1/2	5/8	.59	.13	.70	1.09	.38	.63	.38	.50			
4COS[]	1/4	7/16-20	1.55	9/16	3/4	.64	.19	.77	1.22	.41	.75	.44	.63			
6COS[]	3/8	9/16-18	1.72	11/16	15/16	.72	.30	.83	1.38	.47	.94	.56	.75			
8COS6[]	1/2	9/16-18	1.88	7/8	15/16	.97	.30	.92	1.41	.47	.94	.58	.78			
8COS[]	1/2	3/4-16	1.88	7/8	1 1/8	.97	.42	.92	1.41	.47	1.13	.75	.94			
10COS[]	5/8	7/8-14	1.94	1	1 5/16	1	.50	.92	1.50	.47	1.31	.88	1.13			
12COS[]	3/4	1 1/16-12	2.09	1 1/8	1 1/2	1	.66	.97	1.66	.56	1.50	1.06	1.31			
14COS[]	7/8	1 1/16-12	2.09	1 1/4	1 1/2	1.06	.72	.97	1.66	.56	1.50	1.06	1.31			
16COS[]	1	1 5/16-12	2.38	1 1/2	1 3/4	1.31	.88	1.08	1.81	.56	1.75	1.31	1.56			

O-ring Male Connector: COM

connects fractional tube to female NPT threads

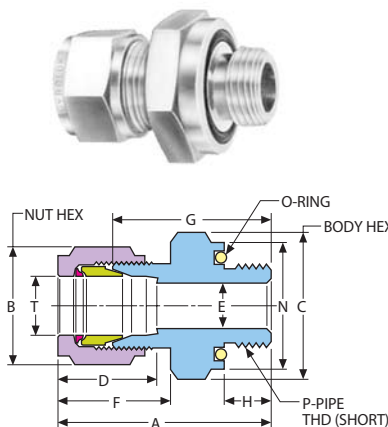

Part Number*	T		P		Dimensions — inches										O-ring	
	Tube O.D.	Pipe Thd.	A	B Hex Flat	C Hex Flat	D	E min	F	G	H	N	I.D.	O.D.			
1COM2[]	1/16	1/8	1.06	5/16	3/4	.41	.05	.48	.84	.28	.75	.44	.63			
2COM2[]	1/8	1/8	1.34	7/16	3/4	.56	.09	.67	1.03	.28	.75	.44	.63			
2COM4[]	1/8	1/4	1.47	7/16	15/16	.56	.09	.67	1.16	.38	.94	.56	.75			
3COM2[]	3/16	1/8	1.38	1/2	3/4	.59	.13	.70	1.06	.28	.75	.44	.63			
3COM4[]	3/16	1/4	1.50	1/2	15/16	.59	.13	.70	1.19	.38	.94	.56	.75			
4COM2[]	1/4	1/8	1.42	9/16	3/4	.64	.19	.77	1.09	.28	.75	.44	.63			
4COM4[]	1/4	1/4	1.55	9/16	15/16	.64	.19	.77	1.22	.38	.94	.56	.75			
4COM6[]	1/4	3/8	1.61	9/16	1 1/8	.64	.19	.77	1.28	.41	1.13	.75	.94			
6COM2[]	3/8	1/8	1.50	11/16	3/4	.72	.19	.83	1.16	.28	.75	.44	.63			
6COM4[]	3/8	1/4	1.63	11/16	15/16	.72	.28	.83	1.28	.38	.94	.56	.75			
6COM6[]	3/8	3/8	1.69	11/16	1 1/8	.72	.28	.83	1.34	.41	1.13	.75	.94			
6COM8[]	3/8	1/2	1.91	11/16	1 5/16	.72	.28	.83	1.56	.53	1.31	.88	1.13			
8COM4[]	1/2	1/4	1.75	7/8	15/16	.97	.28	.92	1.28	.38	.94	.56	.75			
8COM6[]	1/2	3/8	1.81	7/8	1 1/8	.97	.41	.92	1.34	.41	1.13	.75	.94			
8COM8[]	1/2	1/2	2.03	7/8	1 5/16	.97	.41	.92	1.56	.53	1.31	.88	1.13			
10COM8[]	5/8	1/2	2	1	1 5/16	1	.50	.92	1.56	.53	1.31	.88	1.13			
10COM12[]	5/8	3/4	2.09	1	1 1/2	1	.50	.92	1.66	.56	1.50	1.06	1.31			
12COM8[]	3/4	1/2	2	1 1/8	1 5/16	1	.55	.97	1.56	.53	1.31	.88	1.13			
12COM12[]	3/4	3/4	2.09	1 1/8	1 1/2	1	.63	.97	1.66	.56	1.50	1.06	1.31			
16COM12[]	1	3/4	2.31	1 1/2	1 1/2	1.31	.63	1.08	1.75	.56	1.50	1.06	1.31			
16COM16[]	1	1	2.38	1 1/2	1 3/4	1.31	.88	1.08	1.91	.66	1.75	1.31	1.56			

* [] see page 6 for material specifications.

HOKE Dielectric Tube Fittings



The HOKE Gyrolok Dielectric Tube Fittings are for use in applications where electrical current flowing through a pipe or tube line must be interrupted to protect vital instrumentation and metering equipment.

Technical Data

Body Construction Materials:	• 316 Stainless Steel
Insulator:	• Molded Thermoplastic
O-ring Material:	• 90 Durometer Viton
Back-up Washer:	• Virgin TFE

Electrical Resistance of Insulators:	• 7.0 X 10 ⁸ Ω @ 10 Volts DC @ 70° F and 50% relative humidity • 1.0 X 10 ⁶ Ω @ 10 Volts DC @ 100° F and 90% relative humidity
Pressure Rating:	• 4000 PSIG @ 70° F (27,580kPa @ 21° C)
Temperature Rating:	• -40° F to +200° F (-40° C to +93° C)

Design

The Dielectric Tube Fitting must perform three primary functions:

1. Electrical insulation
2. Reliable fluid containment
3. Appropriate flow for line size

In the HOKE design, the insulation function is performed by thermoplastic insulators which provide performance unequaled by any similar product.

A Viton O-ring and TFE back up ring provide the containment function within the fitting.

Gyrolok's 2-ferrule system provides sealing with the impulse line tubing.

Appropriate flow for line size is achieved by providing the appropriate inside diameter for tubing size. See "E" dimensions in Dimensional Table.

WARNING: A "NO WRENCHING" label is placed on the hex of the nut in the insulation sections. Do not disconnect at this point. Instructions are provided with every HOKE Dielectric fitting.

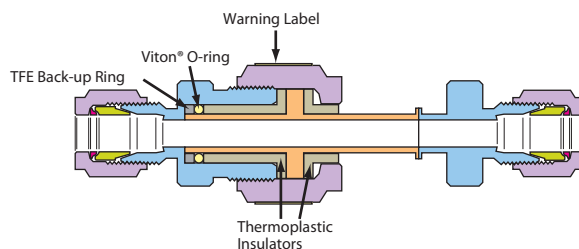

Dielectric Unions: DU

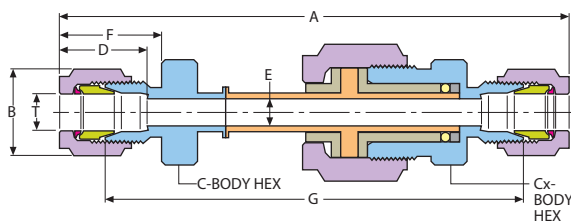

Part No.	T Tube O.D.	Dimensions — inches							
		A	B	C Hex Flat	Cx Hex Flat	D	E min	F	G
4DU-316	1/4	3.78	9/16	1/2	11/16	.64	.19	.77	3.12
6DU-316	3/8	3.92	11/16	5/8	13/16	.72	.28	.83	3.23
8DU-316	1/2	4.15	7/8	13/16	15/16	.97	.42	.92	3.21

Dielectric Male Connectors: DCM

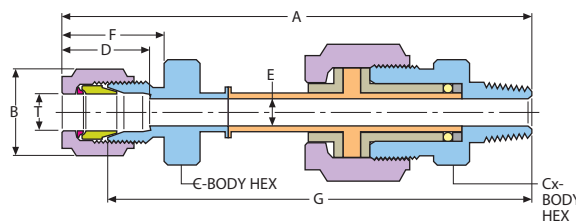

Part No.	T Tube O.D.	Dimensions — inches							
		A	B	C Hex Flat	Cx Hex Flat	D	E min	F	G
6DCM4-316	3/8	3.66	11/16	5/8	13/16	.72	.28	.83	3.32

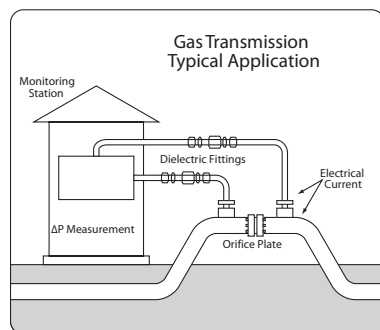

Application

Commonly used in the Natural Gas Transmission industry, the Dielectric Fitting will prevent current flow resulting from Impressed Current Cathodic Protection Systems, static electricity or even lightning strikes, from reaching sensitive monitoring station equipment.

Impressed Current Cathodic Protection Systems involve the application of a low voltage, low amperage direct current to a pipeline and eventual transfer of corrosive effects to a typically underground anode bed.

If the current flow is not interrupted before reaching the monitoring station critical equipment could be damaged or rendered inaccurate.

By installing HOKE's Gyrolok Dielectric Tube Fitting on impulse lines between the pipeline and the monitoring station, current flow is interrupted while full fluid flow is permitted.