

ATKOMATIC

40000 Series

Stainless Steel, Semi-direct Lift, Pressure 0 to 2500 psig (173 bar)
High Temperature High Pressure Valve Configurable for a Variety of Fluid Applications



Features

- Designed for high temperature fluids, maximum nominal temperature rating of 750° F (399° C)
- Operational pressure up to 2500 psi (173 bar)
- Extended neck to locate the solenoid at a distance from the hot fluid flow
- Carbon graphite piston rings
- 316 stainless steel body o-rings
- Pilot seats are made of Stellite® (a cobalt alloy) for temperature and wear resistance
- Piston is made of 17-4 stainless steel and the piston seat is Stellite®
- Available in normally open and normally closed versions
- Mounted with the coil oriented down to minimize convection heating of coil from the hot media
- Stainless steel construction on all pressure containing parts: 316 for machined parts and CF8M for cast parts.
- Plunger material is 416 stainless that is treated for increased corrosion resistance
- Semi-direct lift action for operation down to zero pressure differential
- Will handle fluids with viscosity up to 150 SUS
- Suitable for use with wide variety of fluid including: air, gasses, liquids, hydraulic fluids, steam, and corrosive fluids
- Heaviest duty and most rugged construction
- Removable 316 stainless steel body inserts (stainless steel trim)
- Full ported valves
- Available in normally closed configuration from ¼" to 1½" ports
- Cv from 1.1 to 21.5 in normally closed version
- Available in normally open configuration from ¼" to 1" ports
- Cv from 1.1 to 21.0 in normally open version
- British BSPT ports are available
- Class H coils are standard
- Coil housings available in NEMA 1 (standard), NEMA 4 (waterproof), NEMA 7 (explosion-proof for hazardous locations), and combination NEMA 4 & 7

Circle Seal Controls

2301 Wardlow Circle • P.O. Box 3300 • Corona, CA 92880

Phone (951) 270-6200 Fax (951) 270-6201

www.circlesealcontrols.com • am_sales@circlesealcontrols.com • ind_sales@circlesealcontrols.com

atkomatic solenoid

40000 Series

Operational Pressures (No minimum pressure differential)

Normally closed

ALL GASES		ALL LIQUIDS	
AC	DC	AC	DC
2500 / 173 bar	1500 / 104 bar	2500 / 173 bar	1000 / 69 bar

Normally open

ALL GASES		ALL LIQUIDS	
AC	DC	AC	DC
2500 / 173 bar	2000 / 138 bar	2500 / 173 bar	1500 / 104 bar

Note: The operational pressure is limited to a maximum of 1500 psi (104 bar) when the fluid temperature is between 650° F and 750° F (+343° C and +399° C). The operational pressure is limited to a maximum of 2000 psi (133 bar) when the fluid temperature is between 550° F and 650° F (+288° C and +343° C). For fluid temperatures below 550° F (+288° C) the operational pressure is 2000 psi (138 bar) maximum.

Note: Normally open valves are rated for intermittent duty only on 40000 Series valves.

Note: Normally open 40000 Series valves are not available with 50 Hz coils for operational pressures above 1500 psi (104 bar).

Dimensions, Shipping Weights, and Cv Flow Factors

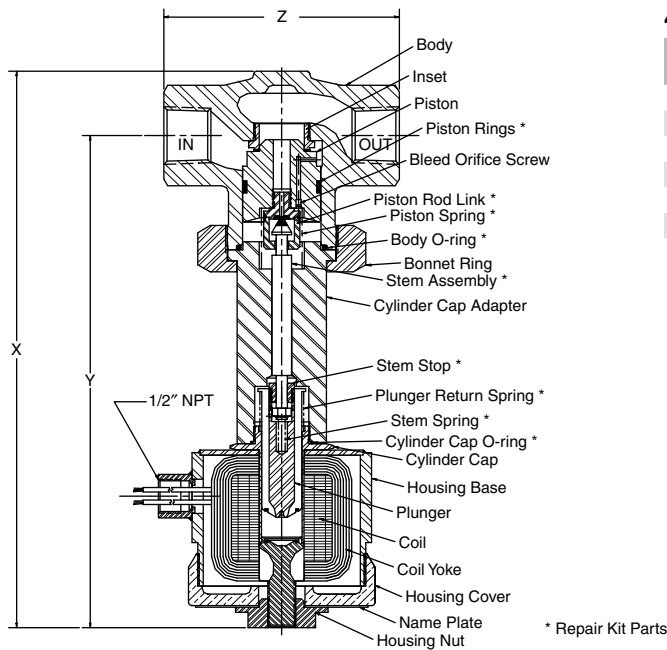

Normally closed 1" 41840 valve, shown with NEMA 7 explosion-proof coil housing and a AC coil

40000 Series Normally Closed

CATALOG NUM. PREFIX	PIPE SIZE	MAIN SEAT ORIFICE	X	Y	Z	SHIPPING WEIGHT (lbs)	Cv
41800	1/4"	3/8"	11 3/8"	10 5/16"	3"	14	1.1
41810	3/8"	1/2"	11 3/8"	10 5/16"	3"	14	2.5
41820	1/2"	3/4"	12 5/16"	10 7/8"	4 3/4"	17	5.1
41830	3/4"	3/4"	12 5/16"	10 7/8"	4 3/4"	17	7.5
41840	1"	1"	12 1/2"	11 1/4"	5 1/4"	23	12.5
41851	1 1/4"	1 1/2"	13 3/8"	13 1/8"	5 3/4"	22	21.0
41861	1 1/2"	1 1/2"	13 3/8"	13 1/8"	5 3/4"	22	21.5

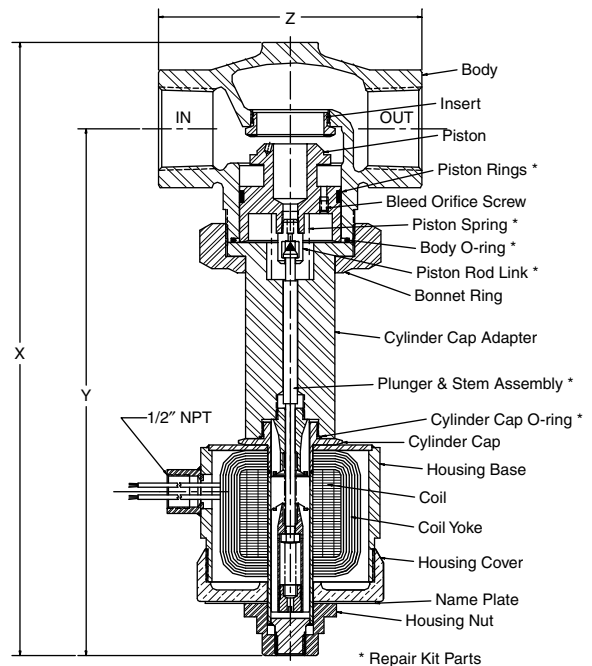

Normally open 1 1/2" 42861 valve, shown with a NEMA 7 explosion-proof coil housing and a AC coil

40000 Series Normally Open

CATALOG NUM. PREFIX	PIPE SIZE	MAIN SEAT ORIFICE	X	Y	Z	SHIPPING WEIGHT (lbs)	Cv
42800	1/4"	3/8"	11 1/2"	10 5/16"	3"	14	1.1
42810	3/8"	1/2"	11 1/2"	10 5/16"	3"	14	2.5
42820	1/2"	3/4"	12 5/16"	11 1/8"	4 3/4"	17	5.1
42830	3/4"	3/4"	12 5/16"	11 1/8"	4 3/4"	17	7.3
42840	1"	1"	13 3/8"	11 1/8"	5 1/4"	23	12.5

40000 Series

How to Order

