

# Coils

## Standard Available Coil Voltages

### Class B coils for JJ, 15–794, and 500 Series Valves

VOLTAGE	PART NUMBER	RESISTANCE ±10%	INRUSH AMPS	HOLDING AMPS	VOLT-AMPS
24 VAC 60 Hz	62197	6.51 Ω	2.11	0.99	51
110 VAC 50 Hz	62191	232.5	0.35	0.17	39
115 VAC 60 Hz	62209	156.4	0.43	0.21	49
220 VAC 50 Hz	62193	955.2	0.17	0.084	37
230 VAC 60 Hz	62199	639.2	0.21	0.10	48
460 VAC 60 Hz	62201	2,517	0.108	0.050	50
12 VDC	62203	9.63		1.26	15
24 VDC	62205	39.67		0.60	15
100 VDC	62199	639.2		0.20	20

### Class H coils for JJ, HS, 15–794, and 500 Series Valves

VOLTAGE	PART NUMBER	RESISTANCE ±10%	INRUSH AMPS	HOLDING AMPS	VOLT-AMPS
24 VAC 60 Hz	62198	6.48	2.10	0.96	50
100 VAC 60 Hz	63599	101.4	0.68	0.35	68
110 VAC 50 Hz	62190	187.6	0.39	0.17	43
115 VAC 60 Hz	62210	140.1	0.52	0.25	60
200 VAC 60 Hz	63600	408.4	0.34	0.17	68
220 VAC 50 Hz	62194	903.0	0.18	0.085	40
230 VAC 60 Hz	62200	498.3	0.31	0.10	71
380 VAC 50 Hz	62202	1,980	0.16	0.075	74
460 VAC 60 Hz	62202	980	0.16	0.075	74
12 VDC	62206	10.17		1.13	14
24 VDC	62186	40.82		0.58	14
32 VDC	62186	40.82		0.74	24
48 VDC	62210	140.1		0.40	19
100 VDC	62200	498.3		0.20	20
125 VDC	62188	706.0		0.17	21
250 VDC	62192	2,986		0.08	20

### Class H coils for 12000 and 14000 Series Valves

VOLTAGE	PART NUMBER	RESISTANCE ±10%	INRUSH AMPS	HOLDING AMPS	VOLT-AMPS
100 VAC 60 Hz	63635	34.5	0.92	0.52	92
110 VAC 50 Hz	62186	40.82	0.98	0.52	108
115 VAC 60 Hz	62186	40.82	0.85	0.34	98
200 VAC 60 Hz	63636	99.3	0.61	0.37	122
220 VAC 50 Hz	62190	187.6	0.36	0.17	79
230 VAC 60 Hz	62210	140.1	0.48	0.24	110
460 VAC 60 Hz	62200	498.3	0.32	0.16	147
12 VDC	62174	4.17		2.7	32
24 VDC	62176	15.92		1.4	34
125 VDC	62178	485.9		0.26	33

### Class B coils for 12000 Series Valves

VOLTAGE	PART NUMBER	RESISTANCE ±10%	INRUSH AMPS	HOLDING AMPS	VOLT-AMPS
110 VAC 50 Hz	62205	39.67	0.98	0.52	108
115 VAC 60 Hz	62205	39.67	0.85	0.34	98
230 VAC 60 Hz	62191	156.4	0.48	0.24	110
460 VAC 60 Hz	62193	639.2	0.32	0.16	147

### Class B coils for 3000, 4000, 5000, 6000, and 15000 Series Valves

VOLTAGE	PART NUMBER	RESISTANCE ±10%	INRUSH AMPS	HOLDING AMPS	VOLT-AMPS
110 VAC 50 Hz	62170	32.25	1.0	0.52	110
115 VAC 60 Hz	62211	23.24	1.14	0.58	131
220 VAC 50 Hz	62181	126.1	0.50	0.26	110
230 VAC 60 Hz	62173	92.9	0.53	0.28	122
380 VAC 50 Hz	62179	381.5	0.28	0.15	129
460 VAC 60 Hz	62179	381.5	0.28	0.15	129

Note: There are no class B coils available in DC voltages for these valve series.

## Class H coils for 1000, 2000, 3000, 4000, 5000, 6000, 8000, 15000, and 16000 Series Valves

VOLTAGE	PART NUMBER	RESISTANCE ±10%	INRUSH AMPS	HOLDING AMPS	VOLT-AMPS
24 VAC 50 Hz	62175	1.25	4.80	2.5	115
24 VAC 60 Hz	62182	0.97	5.73	3.21	138
100 VAC 60 Hz	62171	18.72	1.25	0.60	125
110 VAC 50 Hz	62185	32.33	1.00	0.52	110
115 VAC 60 Hz	62212	23.07	1.14	0.58	131
200 VAC 60 Hz	62172	75.37	0.64	0.31	128
220 VAC 50 Hz	62189	126.4	0.50	0.27	110
230 VAC 60 Hz	62187	92.04	0.54	0.28	131
380 VAC 50 Hz	62177	379.3	0.27	0.14	124
460 VAC 60 Hz	62177	379.3	0.27	0.14	124
12 VDC	62174	4.17		2.94	35
24 VDC	62176	15.92		1.52	36
32 VDC	62185	32.33		0.98	31
72 VDC	62189	126.4		0.55	40
125 VDC	62178	485.9		0.24	30
250 VDC	62180	2,212		0.11	28

For AC valves the maximum possible wattage or power consumption is the volt-amp figure given in the tables. This is the “inrush” condition or the high momentary amperage surge occurring when the coil is energized. After the valve actuates, the current is reduced to a steady state referred to as “holding” current. The maximum possible holding power consumption is the holding volt-amps. This can be calculated by multiplying the voltage times the holding current given in the tables as follows:

$$\text{Holding volt-amps} = \text{Voltage} \times \text{Holding Current} \text{ and } \text{Inrush volt-amps} = \text{Voltage} \times \text{Inrush Current}$$

DC coils do not produce a inrush current higher than the holding current, i.e. the holding current and inrush current are the same. Power consumption or wattage for DC coils can be calculated as follows:

$$\text{Watts} = \text{Voltage} \times \text{Current}$$

## Double Wound Class H coils for 1004, 2004, 7004, 8004, and 16004 Series Valves

VOLTAGE	PART NUMBER	RESISTANCE ±10%	INRUSH AMPS	HOLDING AMPS	VOLT-AMPS	
100 VAC 60 Hz	63603	2.32 p	46.13 s	25.0	0.37	2,500
110 VAC 50 Hz	62163	3.52 p	82.39 s	21.5	0.30	2,365
115 VAC 60 Hz	62161	3.32 p	65.41 s	19.0	0.30	21,85
200 VAC 60 Hz	63596	10.23 p	173.9 s	11.05	0.19	2,210
220 VAC 50 Hz	62162	13.39 p	403.0 s	10.0	0.17	2,200
230 VAC 60 Hz	62160	12.82 p	387.6 s	10.1	0.17	2,323
460 VAC 60 Hz	62168	68.8 p	2,710 s	3.7	0.058	1,702
24 VDC	62164	2.23 p	46.92 s	6.8	0.54	163
32 VDC	62164	2.23 p	46.92 s	6.8	0.54	163
48 VDC	62161	3.32 p	65.41 s	10.0	0.70	480
125 VDC	62166	8.65 p	461.7 s	14.0	0.24	1,750
250 VDC	62168	68.8 p	2,710 s	3.1	0.90	775

## Class H coils for 13000, 30000, 40000, and 50000 Series Valves

VOLTAGE	PART NUMBER	RESISTANCE ±10%	INRUSH AMPS	HOLDING AMPS	VOLT-AMPS
100 VAC 60 Hz	62213-10	7.36	4.3	0.75	430
110 VAC 50 Hz	62213-11	9.91	3.6	0.65	396
115 VAC 60 Hz	62213-1	9.17	3.7	0.66	426
200 VAC 60 Hz	62213-9	28.43	2.5	0.42	500
220 VAC 50 Hz	62213-12	41.50	1.5	0.26	330
230 VAC 60 Hz	62213-5	27.00	2.2	0.38	506
460 VAC 60 Hz	62213-7	111.4	1.05	0.20	483
12 VDC	62216-1	3.10		4.0	48
24 VDC	62216-2	11.53		2.0	48
48 VDC	62216-6	47.82		1.1	53
125 VDC	62216-8	238.4		0.5	63
250 VDC	62216-10	961.8		0.25	63

All resistance and amperage values are given for coils at room temperature (77° F / 25° C).

Note: 50 Hz coils are not available on the 30000, 40000, and 50000 Series valves above 1,500 psig (104 bar)

Note: At a particular voltage 60 Hz coils can only be used on 60 Hz and 50 Hz only on 50 Hz.

Note that the 12000/14000 Series valves use some of the same class H coils as the HS/JJ/500 Series. Since the magnetic circuits external to the coil are substantially different between these two groups of valves the coil performance also differs. This means that those coils which are common to both groups of valves will operate at different voltages in each valve group. For instance, a coil that is used as a 230/60 Hz coil in the HS/JJ/500 valve group is used as a 460/60 Hz coil in the 12000/14000 valve group and a coil that is used at 24 VDC in the HS/JJ/500 group is used at 115/60 Hz in the 12000/14000 group. The DC coils used in the 12000/14000 group are the same as those used in the 1000/2000/3000/4000/5000/15000/16000 group and operate at the same voltages.

When voltage is removed from a coil the magnetic field collapses rapidly and its energy is converted into a voltage surge (sometimes referred to a back EMF). This surge travels back up the power lines and can have peak voltages of several thousand volts.

Usually it is dissipated harmlessly in the form of a spark across switch contacts. Some types of electrical systems, particularly computer components and some instruments, can be adversely affected. In these types of systems surge suppression or isolation using relays is recommended.

## Types of Insulation

The coils used in the ATKOMATIC line are of 2 types of construction:

- 1 A molded construction. These coils are wound on a Nylon bobbin and encapsulated with a polyester plastic. These types of coils are hermetically sealed and suitable for use over a wide temperature range and in humid conditions. The leads are 18 gage stranded wire and are 24 inches in length. They are available in 2 temperature classifications, class H and B. The B class is used extensively in the lower cost bronze valves mainly for competitive purposes and the H class in the more expensive stainless steel valves and where elevated temperatures are involved. All molded coils are Underwriters Laboratories recognized components.
- 2 A fiberglass wrapped construction. These coils are wound and then wrapped with strips of fiberglass cloth and dipped in a resin to bind the assembly. The leads are 18 gage stranded wire and are 18 inches in length. This style coil is used only in double wound coils and all of these are class H. Its usage in all other style valves has been replaced with the molded coils.

Class H coils only are recommended for use in the cast iron NEMA 7 coil housings used on the 2000, 3000, 4000, 5000, 6000, 8000, and 15000 Series valves.

Insulation for coils is rated by the capability to withstand elevated temperatures. Categories common in the electrical industry include:

Class A insulation: 105° C (221° F) temperature rise above an ambient of 25° C (77° F)

Class B insulation: 130° C (266° F) temperature rise above an ambient of 25° C (77° F)

Class F insulation: 155° C (311° F) temperature rise above an ambient of 25° C (77° F)

Class H insulation: 180° C (356° F) temperature rise above an ambient of 25° C (77° F)

These classes indicate a temperature that the insulation is capable of surviving for a specified time. This specified life is not set by any generally recognized standard but is determined by individual manufactures. A typical value used in the industry today is 30,000 hours with all operating parameters at their nominal conditions (voltage at nominal, ambient and fluid at room temperature, etc.). Refer to the section on each valve and the section on creating the catalog number (page 4) for insulation class selection guidelines.

These temperatures are for the coil insulation and windings, not the temperature of the fluid media flowing through the valve. There are several factors, which govern the temperature of a coil in service including the fluid temperature, ambient temperature, duty cycle, coil housing, as well as the coil design itself.

All normally closed valves are designed to function with a voltage applied that is within  $\pm 10\%$  of the nominal value. Normally open valves require a minimum of the voltage for proper operation and can withstand an over-voltage of +10% without damage to the coil (although intermittent operation is required to maintain cool coil temperatures for operation).

All single wound coils have the following wiring diagram:

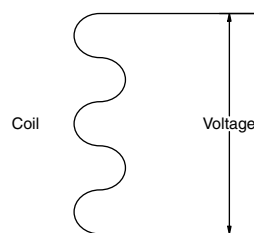

*There is no polarity; i.e. either wire can be positive or negative.*

For proper valve operation, power to the coil should be controlled with a double pole switch

Power supply circuits that contain diodes or capacitors can delay valve closure.

# Double Wound Coils

The double wound coils consist of two coil windings within the same encapsulation. The windings are the primary, which consists of a heavy wire coil with relatively few turns and a low resistance and a secondary coil winding of many turns of fine wire with a high resistance. To open the valve, power is initially applied across the primary winding (red to yellow) and the combination of primary and secondary circuits in series (red to black) as shown schematically:

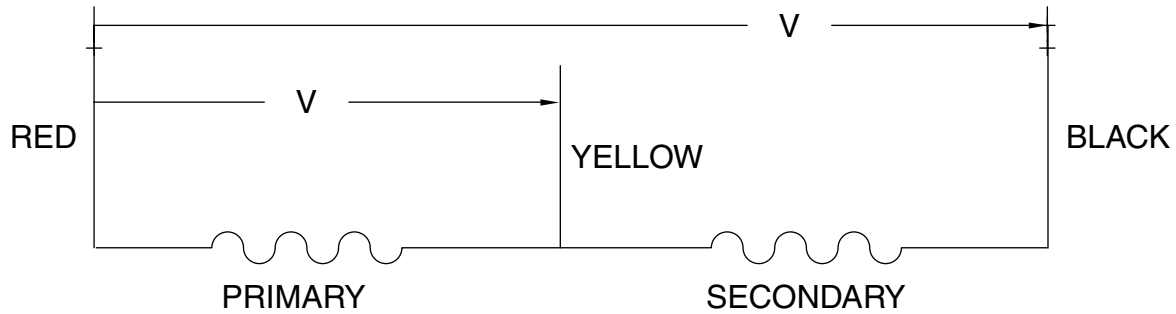

The high current through the primary circuit generates a strong magnetic field that actuates the valve. This current is sufficiently high that the coil would overheat if the current were allowed to continue for more than a few minutes. After a fraction of a second, (the delay is caused by the dropout time of the relay) the yellow lead is disconnected and the voltage remains applied only across the combination of the primary and secondary windings in series. The low current through both windings produces a lower strength magnetic field that is sufficient to hold the valve open. The low current produces only modest heating of the coil allowing the valve to remain actuated open continuously. This steady state condition is shown schematically:

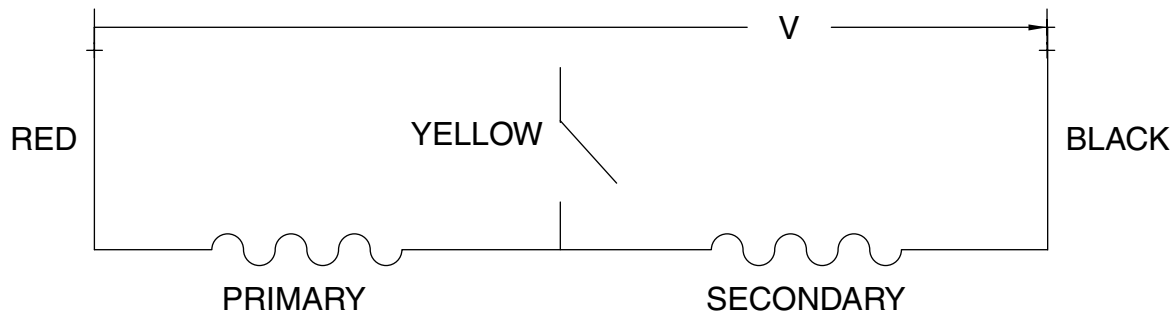

Current production of these coils utilizes a fiberglass wrapping that is dipped in a resin to affect a seal. This insulation is rated class H that means that it can withstand a 180° C temperature rise continuously. The double wound coils require the use of a time delay relay to disconnect the primary coil winding after the valve has actuated. This delay is on the order of 1/2 second. In some cases the customer supplies this timing device and Circle Seal does offer a normally closed relay for this purpose. It is ordered as a separate line item as follows:

## R-x x x

The voltage is coded in the same manner as the valve catalog number that the relays are used with. The following voltages are available:

100 VAC 60 Hz, 110 VAC 50 Hz, 115 VAC 60 Hz, 200 VAC 60 Hz, 220 VAC 50 Hz, 230 VAC 60 Hz,

460 VAC 60 Hz, 24 VDC, 32 VDC, 48 VDC, 125 VDC, and 250 VDC.

The relays are an encapsulated mercury tube design and are supplied mounted in a NEMA 1 electrical enclosure

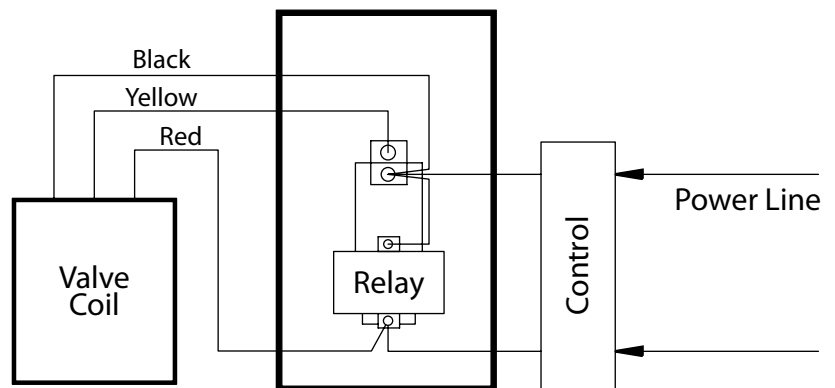

### Mount Vertically

Yellow Lead = Strong Primary Circuit.  
Relay Drop Out Breaks  
Yellow Lead Continuity

*Wiring diagram for the relay*

Double wound coils are used in the following valve series (also included for comparison are performances with both single and double wound coils):

**1000 Series Direct Lift** Normally closed only

1000 1/8" & 1002 1/8"	Single wound coil
1100 1/4" & 1102 1/4"	0–2,500 psi (173 bar), depending on orifice size, fluid, and voltage
1004 1/8" & 1009 1/8"	Double wound coil
1104 1/4" & 1109 1/8"	0–5,000 psi (345 bar), depending on orifice size, fluid, and voltage

**2000 Series Direct Lift** Normally closed only

2000 1/8"	Single wound coil
2300 1/2"	0–2,500 psi (173 bar), depending on orifice size, fluid, and voltage
2004 1/8"	Double wound coil
2304 1/2"	0–10,000 psi (690 bar) depending on orifice size, fluid, and voltage

**7000 Series Pilot Operated** Normally closed only

7004 1/4"	
7104 3/8"	Double wound coil
7204 1/2"	0–6,000 (414 bar) psi depending on fluid and voltage

**8000 Series Pilot Operated**

*Normally closed*

8000 1/4"	Single wound coil
8710 2"	0–1,500 psi (104 bar) depending on fluid and coil voltage (AC or DC)
8004 1/4"	Double wound coil
8604 1 1/4"	0–4,000 psi (276 bar) depending on fluid and coil voltage (AC or DC)

*Normally open*

8001 1/4"	Single wound coil
8711 2"	0–1,500 psi (104 bar) depending on fluid and coil voltage (AC or DC)

**16000 Series Direct Lift**

*Normally closed*

16000 1/4"	Single wound coil
16400 1"	0–2,500 psi (173 bar) depending on orifice size, fluid
16004 1/4"	Double wound coil
16404 1"	0–6,000 psi (414 bar) depending on orifice size, fluid, and voltage

*Normally open*

16001 1/4"	Single wound coil
16401 1"	0–1,500 psi (104 bar) depending on orifice size, fluid, and voltage