

ATKOMATIC

ATKOMATIC Solenoid Valves

Technical Manual

Index

Application		Response Times & Life Cycle Capability.....	16
Operational Pressures.....	1	Approvals , UL & CSA.....	17
Fluid Filtration Requirements.....	1	Position Indicator Switch Adjustment.....	18
Ambient Air Temperature Requirements.....	1	Aligning Coil Housings.....	18
Installation & General Information.....	1	Field Modifications	
Coils		Coil Changes.....	19
Voltages, Part Numbers, Amps, Resistance.....	3	AC to DC & DC to AC.....	19
Insulation Ratings.....	5	Other Modifications.....	19
Double Wound Coils Operation.....	6	Valve Operation	
Relays for Double Wound Coils.....	6	Direct Lift, Normally Closed.....	20
Coil Housings		Direct Lift, Normally Open.....	20
NEMA 1.....	8	Pilot Operated, Normally Closed.....	20
NEMA 4.....	8	Pilot Operated, Normally Open.....	21
NEMA 7.....	8	Semi-direct Lift, Normally Closed.....	21
NEMA 9.....	8	Semi-direct Lift, Normally Open.....	22
Hazardous Locations.....	12	3-way, Direct Lift.....	22
Valve Sizing & Cv Flow Coefficients.....	13	35000 Series, Externally Piloted.....	22
Factory Leakage Standards.....	15		



atkomatic solenoid

Circle Seal Controls

2301 Wardlow Circle • P.O. Box 3300 • Corona, CA 92880

Phone (909) 270-6200 Fax (909) 270-6201

www.circle-seal.com

Technical Information

Operational pressures for ATKOMATIC valves

Operational pressures are sometimes referred to as differential pressures, maximum differential pressure, or maximum operational pressure differential (MOPD). All of these terms can be used interchangeably on the ATKOMATIC product line. Operational pressures are given for several categories of fluids. These are divided up by viscosity as follows:

- a Gas: this includes all types of fluids that remain in the gaseous state during flow through the valve. Typical examples include air, nitrogen, natural gas, helium, argon, hydrogen, helium, etc.
- b Low viscosity liquid: all liquid fluids up to a viscosity of 40 SUS (4.3 centistokes) such as water, mineral oil, gasoline, kerosene, Diesel and fuel oil #2, JP-4 and other light oils depending on their temperature
- c High viscosity liquid: all liquid fluids from a viscosity of 41 SUS to 150 SUS (32 centistokes) [200 SUS for some valves (42 centistokes)] such as light to medium weight oils depending on their temperature (hydraulic fluids such as MIL-5606, Diesel and fuel oil #3, 4, & 5, S.A.E #10 weight oil).
- d Steam: these are broken out separately due to the temperature limitations of the valves rather than their ability to open against a particular pressure.
- e Cryogenic fluids: includes all fluids that can be in either a liquid or gaseous state such as liquid nitrogen, liquid oxygen, liquid hydrogen, liquid argon, CO₂, etc. When looking up a pull-off value for a cryogenic fluid, use the value given for a liquid up to 40 SUS.

Note: In cases where the fluid can exist at either a liquid or gaseous state, select a cryogenic make-up regardless of the temperatures involved. An example of this would be butane, which can be a gas or liquid depending on pressure at temperatures at or near room temperature.

All of the operational pressures for normally closed valves given are for valves that have been energized continuously, i.e., have coils which have stabilized at a high (above ambient) temperature. Since the resistance of the copper windings increase with temperature, the current is less at elevated temperatures and the strength of the magnetic field is less resulting in lower operational pressures. This effect is especially pronounced in many of the DC coils. The result of this method of rating the valves operational pressures is that the values are conservative for applications where the coils are only intermittently energized and all other operating conditions are nominal.

These pressure ratings do not consider factors such as variations of the voltage applied to the coil or ambient temperatures. The limits of application conditions given in the literature should not be construed to imply that the valves would function under all combinations of adverse conditions. For instance, if after the coil energized continuously, the ambient temperature is at 100° F, and the voltage is dropped to 90% of nominal the valve may not function at its maximum rated pressure. Other combinations of adverse conditions may cause similar effects.

Fluid Filtration Requirements

Contamination in fluid systems is the largest single cause of operational problems. Frequently contamination is present in new systems from sources such as pipe sealant, pipe scale, weld slag, and metallic particles from the assembly of pipe fittings. Flushing of new systems is important to reduce the occurrence of problems, however often even through flushing will not eliminate all contaminants that will break loose during the initial operation of a new system. Filters are an essential component in many systems to prevent valve problems. It is important to locate filters immediately upstream of the valves and to size the filter rating correctly. A maximum micron rating to provide adequate protection is 40 microns. Note that strainers or screens are generally not capable of providing this degree of filtration and a filter with a depth type of element is necessary.

Ambient Air Temperature Requirements

All the ATKOMATIC valve series are designed to operate with ambient temperatures up to 40° C (104° F) with class H coils. Ambient temperatures above this will adversely affect coil life. Note that for this ambient temperature to be maintained around the coils, it may be necessary to provide insulation, shielding, and/or air motion to prevent the valve bodies and associated piping from heating the air surrounding the coil above these limits when fluid temperatures are elevated. This heating effect is more pronounced in larger valves. Class B coils are not recommended for applications where the ambient air will be above 25° C (77° F).

None of the solenoid valves are designed to operate with an external vacuum. The coils rely on convection for cooling and this cooling effect is not present in a vacuum.

Installation and General Information

Most ATKOMATIC valves are designed to be mounted in a horizontal stationary line with the coil on top (within ±10 degrees). The exceptions are: 12000, 13000, and 14000 Series, which may be mounted in any orientation, and the 40000 and 50000 Series valve, which are designed to be installed in a horizontal stationary line with the coil on the bottom (within ±10 degrees).

All ATKOMATIC valves are designed to hold pressure in one direction only. Under a reverse delta pressure all valves will exhibit reverse flow. With pilot operated and semi-direct lift valves, a reverse pressure will push the pilot valve open and pressurize the cavity above the piston. This will prevent the piston from opening and the valve from flowing freely in the reverse direction. Reverse pilot flow will always be present and the volume of flow will depend on the reverse pressure and the diameter of the

pilot orifice. It is possible to modify the valve such that full flow is allowed in the reverse direction (see the Cv feature option on page 88). A direct lift valve will always produce a back flow under a negative or reverse delta pressure condition. It is not possible to prevent all reverse flow without the installation of a check valve in the line.

All direct acting and semi-direct lift valves are suitable for vacuum service. The valves will function normally with any level of vacuum at the outlet port. However, globe style valves, cast components, brass material, and some elastomers are often not appropriate for use with extremely low vacuums.

ATKOMATIC valves must be mounted with the valve in the line such that the arrow cast into the valve body is in the direction of flow (or with the ports connected as marked for barstock body valves).

To prevent system instability, do not locate valves immediately downstream of pressure or flow control components such as regulators. Pilot operated and semi-direct lift valves should be the same size as the system plumbing. Use of inlet plumbing smaller than the valve size (or other system restrictions) can result in unreliable valve operation including instability (valve oscillation).

For more detailed instructions see the Installation, operating, & troubleshooting instructions for the specific valve series. These are available from the factory, authorized distributors, and on the Internet at <http://www.circle-seal.com/atkomatic.html>.

Coils

Standard Available Coil Voltages

Class B coils for JJ, 15–794, and 500 Series Valves

VOLTAGE	PART NUMBER	RESISTANCE ±10%	INRUSH AMPS	HOLDING AMPS	VOLT-AMPS
24 VAC 60 Hz	62197	6.51 Ω	2.11	0.99	51
110 VAC 50 Hz	62191	232.5	0.35	0.17	39
115 VAC 60 Hz	62209	156.4	0.43	0.21	49
220 VAC 50 Hz	62193	955.2	0.17	0.084	37
230 VAC 60 Hz	62199	639.2	0.21	0.10	48
460 VAC 60 Hz	62201	2,517	0.108	0.050	50
12 VDC	62203	9.63		1.26	15
24 VDC	62205	39.67		0.60	15
100 VDC	62199	639.2		0.20	20

Class H coils for JJ, HS, 15–794, and 500 Series Valves

VOLTAGE	PART NUMBER	RESISTANCE ±10%	INRUSH AMPS	HOLDING AMPS	VOLT-AMPS
24 VAC 60 Hz	62198	6.48	2.10	0.96	50
100 VAC 60 Hz	63599	101.4	0.68	0.35	68
110 VAC 50 Hz	62190	187.6	0.39	0.17	43
115 VAC 60 Hz	62210	140.1	0.52	0.25	60
200 VAC 60 Hz	63600	408.4	0.34	0.17	68
220 VAC 50 Hz	62194	903.0	0.18	0.085	40
230 VAC 60 Hz	62200	498.3	0.31	0.10	71
380 VAC 50 Hz	62202	1,980	0.16	0.075	74
460 VAC 60 Hz	62202	980	0.16	0.075	74
12 VDC	62206	10.17		1.13	14
24 VDC	62186	40.82		0.58	14
32 VDC	62186	40.82		0.74	24
48 VDC	62210	140.1		0.40	19
100 VDC	62200	498.3		0.20	20
125 VDC	62188	706.0		0.17	21
250 VDC	62192	2,986		0.08	20

Class H coils for 12000 and 14000 Series Valves

VOLTAGE	PART NUMBER	RESISTANCE ±10%	INRUSH AMPS	HOLDING AMPS	VOLT-AMPS
100 VAC 60 Hz	63635	34.5	0.92	0.52	92
110 VAC 50 Hz	62186	40.82	0.98	0.52	108
115 VAC 60 Hz	62186	40.82	0.85	0.34	98
200 VAC 60 Hz	63636	99.3	0.61	0.37	122
220 VAC 50 Hz	62190	187.6	0.36	0.17	79
230 VAC 60 Hz	62210	140.1	0.48	0.24	110
460 VAC 60 Hz	62200	498.3	0.32	0.16	147
12 VDC	62174	4.17		2.7	32
24 VDC	62176	15.92		1.4	34
125 VDC	62178	485.9		0.26	33

Class B coils for 12000 Series Valves

VOLTAGE	PART NUMBER	RESISTANCE ±10%	INRUSH AMPS	HOLDING AMPS	VOLT-AMPS
110 VAC 50 Hz	62205	39.67	0.98	0.52	108
115 VAC 60 Hz	62205	39.67	0.85	0.34	98
230 VAC 60 Hz	62191	156.4	0.48	0.24	110
460 VAC 60 Hz	62193	639.2	0.32	0.16	147

Class B coils for 3000, 4000, 5000, 6000, and 15000 Series Valves

VOLTAGE	PART NUMBER	RESISTANCE ±10%	INRUSH AMPS	HOLDING AMPS	VOLT-AMPS
110 VAC 50 Hz	62170	32.25	1.0	0.52	110
115 VAC 60 Hz	62211	23.24	1.14	0.58	131
220 VAC 50 Hz	62181	126.1	0.50	0.26	110
230 VAC 60 Hz	62173	92.9	0.53	0.28	122
380 VAC 50 Hz	62179	381.5	0.28	0.15	129
460 VAC 60 Hz	62179	381.5	0.28	0.15	129

Note: There are no class B coils available in DC voltages for these valve series.

Class H coils for 1000, 2000, 3000, 4000, 5000, 6000, 8000, 15000, and 16000 Series Valves

VOLTAGE	PART NUMBER	RESISTANCE ±10%	INRUSH AMPS	HOLDING AMPS	VOLT-AMPS
24 VAC 50 Hz	62175	1.25	4.80	2.5	115
24 VAC 60 Hz	62182	0.97	5.73	3.21	138
100 VAC 60 Hz	62171	18.72	1.25	0.60	125
110 VAC 50 Hz	62185	32.33	1.00	0.52	110
115 VAC 60 Hz	62212	23.07	1.14	0.58	131
200 VAC 60 Hz	62172	75.37	0.64	0.31	128
220 VAC 50 Hz	62189	126.4	0.50	0.27	110
230 VAC 60 Hz	62187	92.04	0.54	0.28	131
380 VAC 50 Hz	62177	379.3	0.27	0.14	124
460 VAC 60 Hz	62177	379.3	0.27	0.14	124
12 VDC	62174	4.17		2.94	35
24 VDC	62176	15.92		1.52	36
32 VDC	62185	32.33		0.98	31
72 VDC	62189	126.4		0.55	40
125 VDC	62178	485.9		0.24	30
250 VDC	62180	2,212		0.11	28

For AC valves the maximum possible wattage or power consumption is the volt-amp figure given in the tables. This is the “inrush” condition or the high momentary amperage surge occurring when the coil is energized. After the valve actuates, the current is reduced to a steady state referred to as “holding” current. The maximum possible holding power consumption is the holding volt-amps. This can be calculated by multiplying the voltage times the holding current given in the tables as follows:

$$\text{Holding volt-amps} = \text{Voltage} \times \text{Holding Current} \text{ and } \text{Inrush volt-amps} = \text{Voltage} \times \text{Inrush Current}$$

DC coils do not produce a inrush current higher than the holding current, i.e. the holding current and inrush current are the same. Power consumption or wattage for DC coils can be calculated as follows:

$$\text{Watts} = \text{Voltage} \times \text{Current}$$

Double Wound Class H coils for 1004, 2004, 7004, 8004, and 16004 Series Valves

VOLTAGE	PART NUMBER	RESISTANCE ±10%	INRUSH AMPS	HOLDING AMPS	VOLT-AMPS	
100 VAC 60 Hz	63603	2.32 p	46.13 s	25.0	0.37	2,500
110 VAC 50 Hz	62163	3.52 p	82.39 s	21.5	0.30	2,365
115 VAC 60 Hz	62161	3.32 p	65.41 s	19.0	0.30	21,85
200 VAC 60 Hz	63596	10.23 p	173.9 s	11.05	0.19	2,210
220 VAC 50 Hz	62162	13.39 p	403.0 s	10.0	0.17	2,200
230 VAC 60 Hz	62160	12.82 p	387.6 s	10.1	0.17	2,323
460 VAC 60 Hz	62168	68.8 p	2,710 s	3.7	0.058	1,702
24 VDC	62164	2.23 p	46.92 s	6.8	0.54	163
32 VDC	62164	2.23 p	46.92 s	6.8	0.54	163
48 VDC	62161	3.32 p	65.41 s	10.0	0.70	480
125 VDC	62166	8.65 p	461.7 s	14.0	0.24	1,750
250 VDC	62168	68.8 p	2,710 s	3.1	0.90	775

Class H coils for 13000, 30000, 40000, and 50000 Series Valves

VOLTAGE	PART NUMBER	RESISTANCE ±10%	INRUSH AMPS	HOLDING AMPS	VOLT-AMPS
100 VAC 60 Hz	62213-10	7.36	4.3	0.75	430
110 VAC 50 Hz	62213-11	9.91	3.6	0.65	396
115 VAC 60 Hz	62213-1	9.17	3.7	0.66	426
200 VAC 60 Hz	62213-9	28.43	2.5	0.42	500
220 VAC 50 Hz	62213-12	41.50	1.5	0.26	330
230 VAC 60 Hz	62213-5	27.00	2.2	0.38	506
460 VAC 60 Hz	62213-7	111.4	1.05	0.20	483
12 VDC	62216-1	3.10		4.0	48
24 VDC	62216-2	11.53		2.0	48
48 VDC	62216-6	47.82		1.1	53
125 VDC	62216-8	238.4		0.5	63
250 VDC	62216-10	961.8		0.25	63

All resistance and amperage values are given for coils at room temperature (77° F / 25° C).

Note: 50 Hz coils are not available on the 30000, 40000, and 50000 Series valves above 1,500 psig (104 bar)

Note: At a particular voltage 60 Hz coils can only be used on 60 Hz and 50 Hz only on 50 Hz.

Note that the 12000/14000 Series valves use some of the same class H coils as the HS/JJ/500 Series. Since the magnetic circuits external to the coil are substantially different between these two groups of valves the coil performance also differs. This means that those coils which are common to both groups of valves will operate at different voltages in each valve group. For instance, a coil that is used as a 230/60 Hz coil in the HS/JJ/500 valve group is used as a 460/60 Hz coil in the 12000/14000 valve group and a coil that is used at 24 VDC in the HS/JJ/500 group is used at 115/60 Hz in the 12000/14000 group. The DC coils used in the 12000/14000 group are the same as those used in the 1000/2000/3000/4000/5000/15000/16000 group and operate at the same voltages.

When voltage is removed from a coil the magnetic field collapses rapidly and its energy is converted into a voltage surge (sometimes referred to a back EMF). This surge travels back up the power lines and can have peak voltages of several thousand volts.

Usually it is dissipated harmlessly in the form of a spark across switch contacts. Some types of electrical systems, particularly computer components and some instruments, can be adversely affected. In these types of systems surge suppression or isolation using relays is recommended.

Types of Insulation

The coils used in the ATKOMATIC line are of 2 types of construction:

- 1 A molded construction. These coils are wound on a Nylon bobbin and encapsulated with a polyester plastic. These types of coils are hermetically sealed and suitable for use over a wide temperature range and in humid conditions. The leads are 18 gage stranded wire and are 24 inches in length. They are available in 2 temperature classifications, class H and B. The B class is used extensively in the lower cost bronze valves mainly for competitive purposes and the H class in the more expensive stainless steel valves and where elevated temperatures are involved. All molded coils are Underwriters Laboratories recognized components.
- 2 A fiberglass wrapped construction. These coils are wound and then wrapped with strips of fiberglass cloth and dipped in a resin to bind the assembly. The leads are 18 gage stranded wire and are 18 inches in length. This style coil is used only in double wound coils and all of these are class H. Its usage in all other style valves has been replaced with the molded coils.

Class H coils only are recommended for use in the cast iron NEMA 7 coil housings used on the 2000, 3000, 4000, 5000, 6000, 8000, and 15000 Series valves.

Insulation for coils is rated by the capability to withstand elevated temperatures. Categories common in the electrical industry include:

Class A insulation: 105° C (221° F) temperature rise above an ambient of 25° C (77° F)

Class B insulation: 130° C (266° F) temperature rise above an ambient of 25° C (77° F)

Class F insulation: 155° C (311° F) temperature rise above an ambient of 25° C (77° F)

Class H insulation: 180° C (356° F) temperature rise above an ambient of 25° C (77° F)

These classes indicate a temperature that the insulation is capable of surviving for a specified time. This specified life is not set by any generally recognized standard but is determined by individual manufactures. A typical value used in the industry today is 30,000 hours with all operating parameters at their nominal conditions (voltage at nominal, ambient and fluid at room temperature, etc.). Refer to the section on each valve and the section on creating the catalog number (page 4) for insulation class selection guidelines.

These temperatures are for the coil insulation and windings, not the temperature of the fluid media flowing through the valve. There are several factors, which govern the temperature of a coil in service including the fluid temperature, ambient temperature, duty cycle, coil housing, as well as the coil design itself.

All normally closed valves are designed to function with a voltage applied that is within $\pm 10\%$ of the nominal value. Normally open valves require a minimum of the voltage for proper operation and can withstand an over-voltage of +10% without damage to the coil (although intermittent operation is required to maintain cool coil temperatures for operation).

All single wound coils have the following wiring diagram:

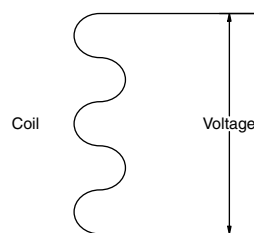

There is no polarity; i.e. either wire can be positive or negative.

For proper valve operation, power to the coil should be controlled with a double pole switch

Power supply circuits that contain diodes or capacitors can delay valve closure.

Double Wound Coils

The double wound coils consist of two coil windings within the same encapsulation. The windings are the primary, which consists of a heavy wire coil with relatively few turns and a low resistance and a secondary coil winding of many turns of fine wire with a high resistance. To open the valve, power is initially applied across the primary winding (red to yellow) and the combination of primary and secondary circuits in series (red to black) as shown schematically:

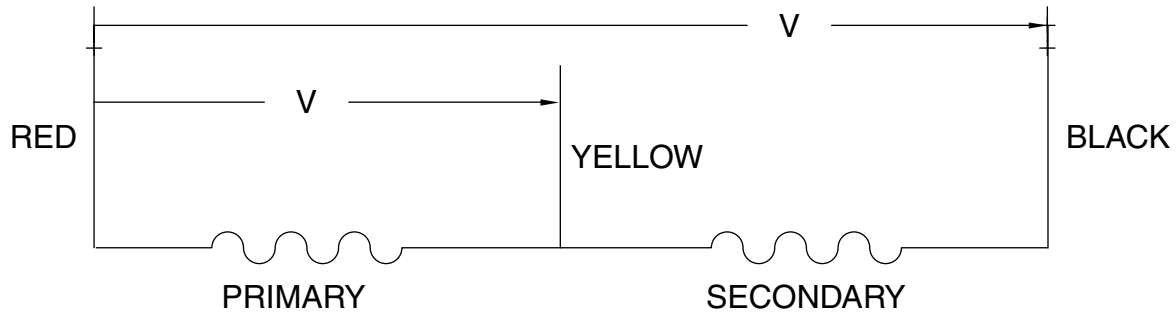

The high current through the primary circuit generates a strong magnetic field that actuates the valve. This current is sufficiently high that the coil would overheat if the current were allowed to continue for more than a few minutes. After a fraction of a second, (the delay is caused by the dropout time of the relay) the yellow lead is disconnected and the voltage remains applied only across the combination of the primary and secondary windings in series. The low current through both windings produces a lower strength magnetic field that is sufficient to hold the valve open. The low current produces only modest heating of the coil allowing the valve to remain actuated open continuously. This steady state condition is shown schematically:

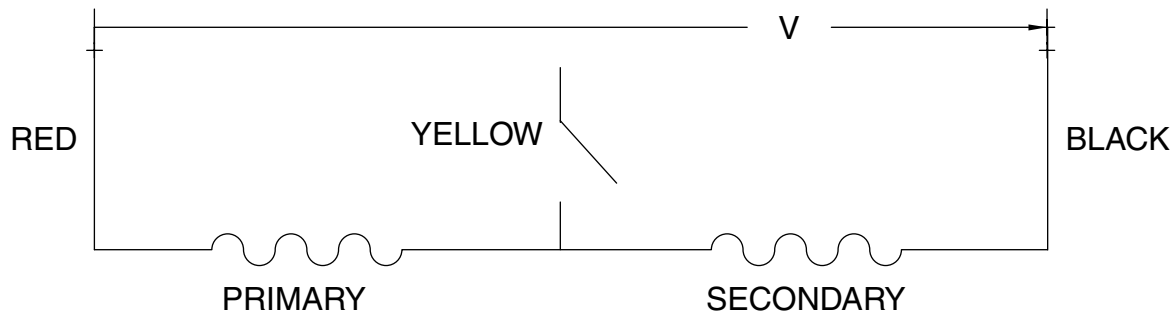

Current production of these coils utilizes a fiberglass wrapping that is dipped in a resin to affect a seal. This insulation is rated class H that means that it can withstand a 180° C temperature rise continuously. The double wound coils require the use of a time delay relay to disconnect the primary coil winding after the valve has actuated. This delay is on the order of 1/2 second. In some cases the customer supplies this timing device and Circle Seal does offer a normally closed relay for this purpose. It is ordered as a separate line item as follows:

R-x x x

The voltage is coded in the same manner as the valve catalog number that the relays are used with. The following voltages are available:

100 VAC 60 Hz, 110 VAC 50 Hz, 115 VAC 60 Hz, 200 VAC 60 Hz, 220 VAC 50 Hz, 230 VAC 60 Hz,

460 VAC 60 Hz, 24 VDC, 32 VDC, 48 VDC, 125 VDC, and 250 VDC.

The relays are an encapsulated mercury tube design and are supplied mounted in a NEMA 1 electrical enclosure

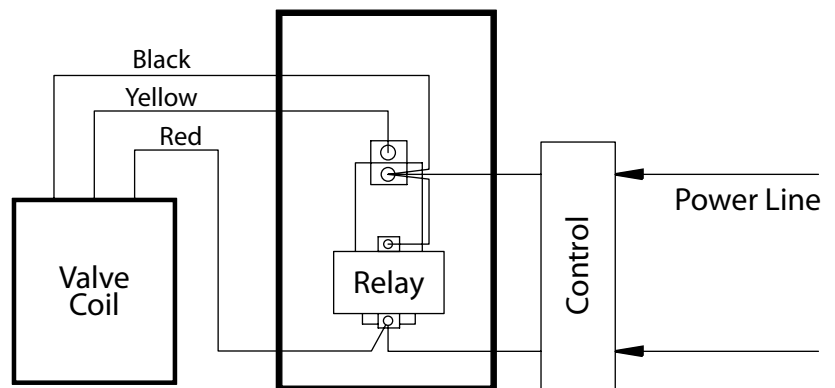

Mount Vertically

Yellow Lead = Strong Primary Circuit.
Relay Drop Out Breaks
Yellow Lead Continuity

Wiring diagram for the relay

Double wound coils are used in the following valve series (also included for comparison are performances with both single and double wound coils):

1000 Series Direct Lift Normally closed only

1000 1/8" & 1002 1/8"	Single wound coil
1100 1/4" & 1102 1/4"	0–2,500 psi (173 bar), depending on orifice size, fluid, and voltage
1004 1/8" & 1009 1/8"	Double wound coil
1104 1/4" & 1109 1/8"	0–5,000 psi (345 bar), depending on orifice size, fluid, and voltage

2000 Series Direct Lift Normally closed only

2000 1/8"	Single wound coil
2300 1/2"	0–2,500 psi (173 bar), depending on orifice size, fluid, and voltage
2004 1/8"	Double wound coil
2304 1/2"	0–10,000 psi (690 bar) depending on orifice size, fluid, and voltage

7000 Series Pilot Operated Normally closed only

7004 1/4"	
7104 3/8"	Double wound coil
7204 1/2"	0–6,000 (414 bar) psi depending on fluid and voltage

8000 Series Pilot Operated

Normally closed

8000 1/4"	Single wound coil
8710 2"	0–1,500 psi (104 bar) depending on fluid and coil voltage (AC or DC)
8004 1/4"	Double wound coil
8604 1 1/4"	0–4,000 psi (276 bar) depending on fluid and coil voltage (AC or DC)

Normally open

8001 1/4"	Single wound coil
8711 2"	0–1,500 psi (104 bar) depending on fluid and coil voltage (AC or DC)

16000 Series Direct Lift

Normally closed

16000 1/4"	Single wound coil
16400 1"	0–2,500 psi (173 bar) depending on orifice size, fluid
16004 1/4"	Double wound coil
16404 1"	0–6,000 psi (414 bar) depending on orifice size, fluid, and voltage

Normally open

16001 1/4"	Single wound coil
16401 1"	0–1,500 psi (104 bar) depending on orifice size, fluid, and voltage

Coil Housings

The National Electrical Equipment Manufacturers Association defines the various types of electrical enclosures used as follows:

NEMA 1 enclosures are intended for indoor use primarily to provide a degree of protection against contact with the enclosed equipment in locations where unusual service conditions do not exist. They provide a degree of protection against limited amounts of falling dirt but will not prevent the entry of dust or liquids. They prevent the insertion of a straight rod of a specified diameter into the equipment cavity of the enclosure.

NEMA 4 enclosures are intended for indoor or outdoor use primarily to provide a degree of protection against windblown dust and rain, splashing water, and hose directed water.

NEMA 7 enclosures are used in hazardous locations and are designed to contain an internal explosion without causing an external hazard. Type 7 enclosures are intended for indoor use and are capable of withstanding the pressures resulting from an internal explosion of specified gasses and contain such an explosion sufficiently that an explosive gas-air mixture existing in the atmosphere surrounding the enclosure will not be ignited. In operation, external surfaces do not reach temperatures capable of igniting explosive gas-air mixtures in the surrounding atmosphere.

NEMA 9 enclosures prevent the entrance of dust and external surfaces do not reach temperatures capable of igniting explosive dust-air mixtures in the surrounding atmosphere. Type 9 enclosures are intended for indoor usage.

In the ATKOMATIC line, combination NEMA 7 or 9 and 4 enclosures combine the features of waterproof and explosion-proof housings and are intended for either indoor or outdoor usage. Additionally, the NEMA 4 housings meet the requirements of NEMA 2 and 3 that provide lesser degrees of protection from water.

All electrical connections are 1/2" NPT

Note: Plungers, coils, and cylinder caps are not considered to be part of coil housing subassemblies, but are shown in some of the following cross sections.

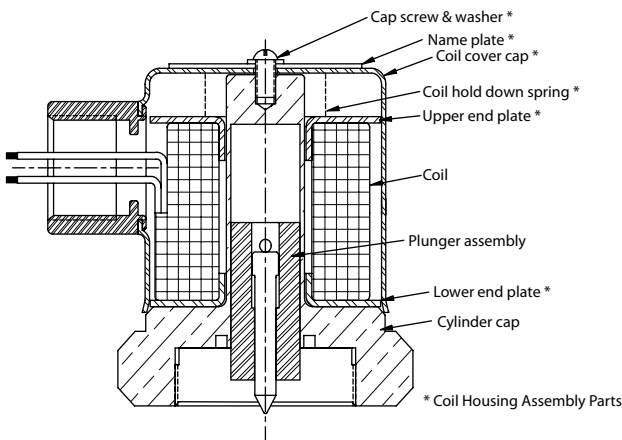

Standard NEMA 1 coil housing option for the following valve series: JJ, HS, and 500
(See page 17 for a cross section of the NEMA 1 housing used on normally open 500 Series valves)

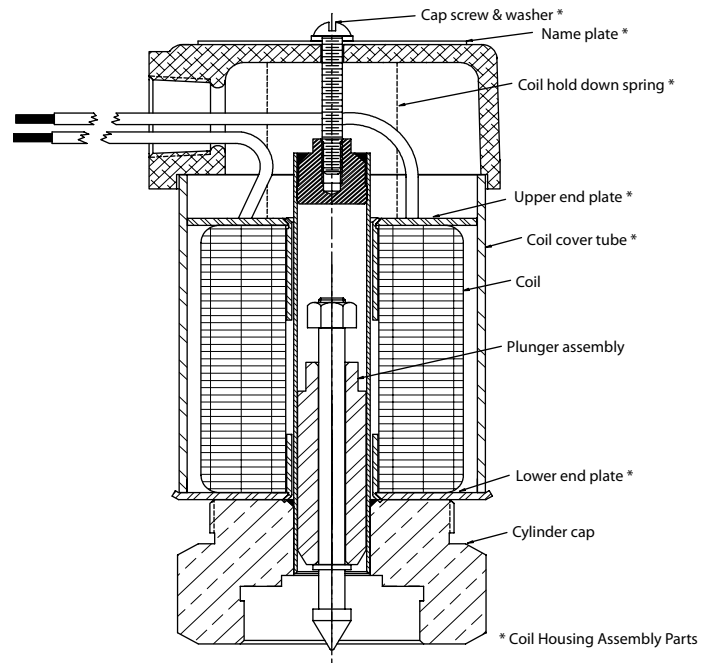

Standard NEMA 1 coil housing option for the following valve series:
2000, 3000, 4000, 5000, 6000, 7000, 8000, 15400, 15800, 16000

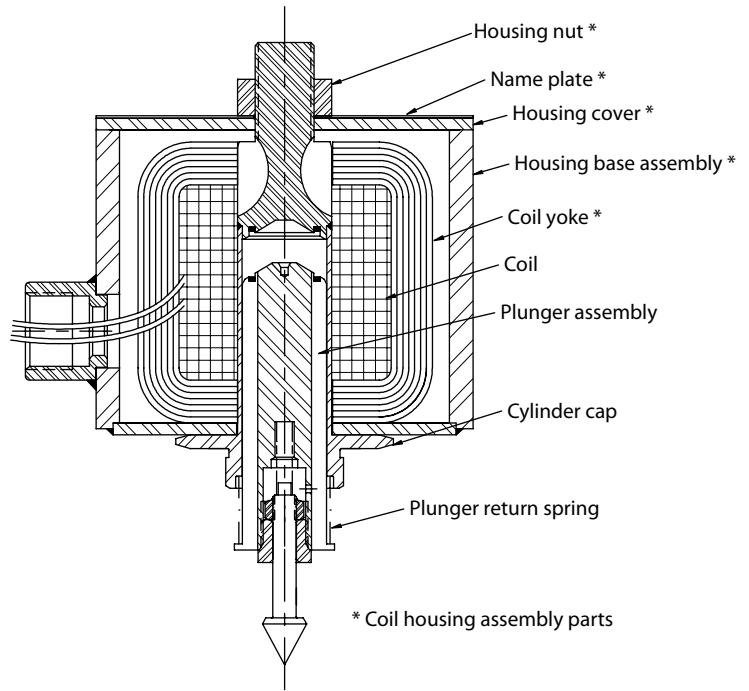

Shown with a AC coil
 Standard NEMA 1 coil housing option for the following valve series:
 13000, 30400, 30800, 35000, 40000, and 50000

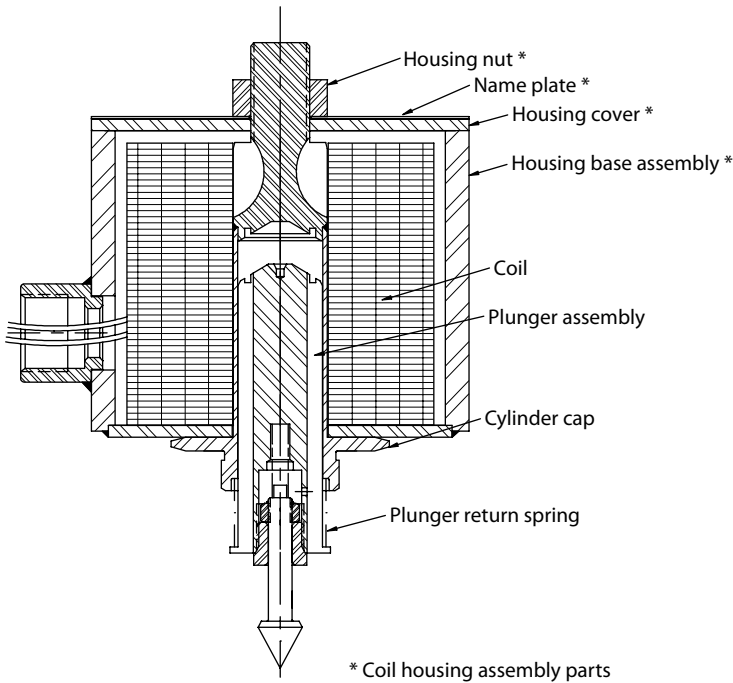

Shown with a DC coil
 Standard NEMA 1 coil housing option for the following valve series:
 13000, 30400, 30800, 35000, 40000, and 50000

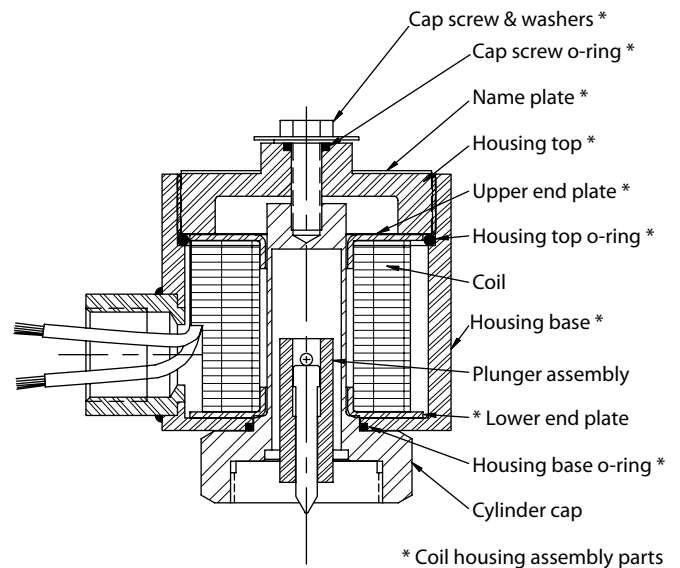

Waterproof NEMA 4 coil housing option for the 500 valve series
 (is standard on the 15-794 valve).

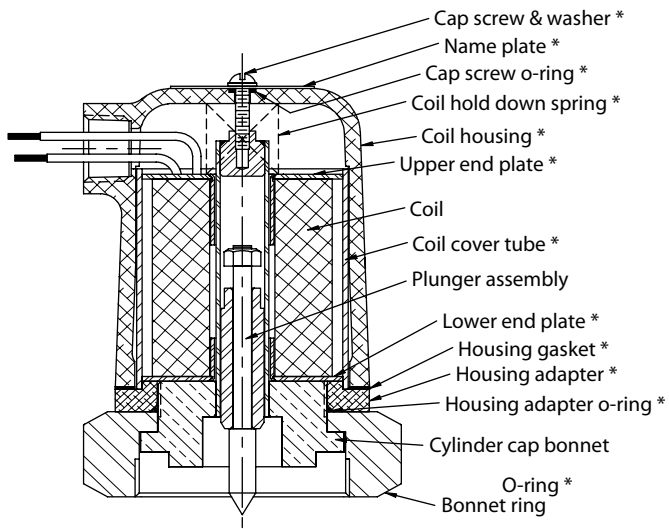

* Coil housing assembly parts

Waterproof NEMA 4 coil housing option for the following normally closed valve series:
2000, 3000, 4000, 5000, 6000, 7000, 8000, 15400, 15800, 16000

Note that there are some minor differences among housings used on these valves

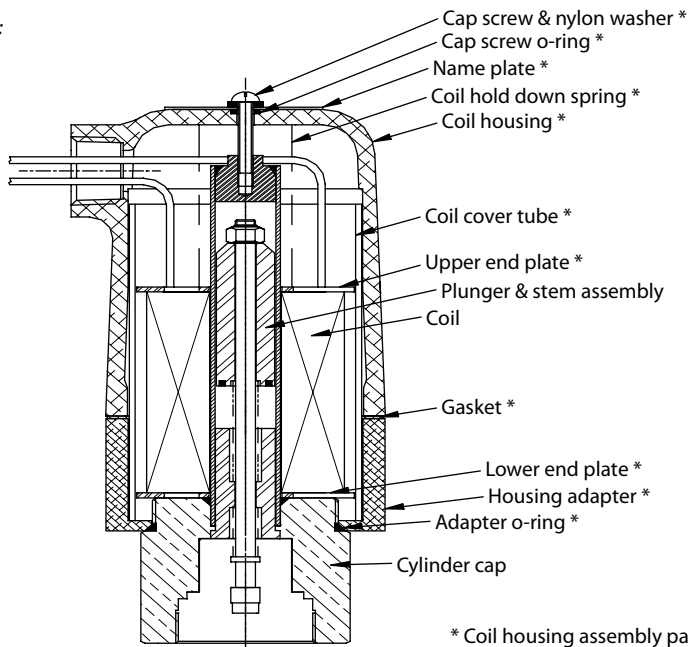

* Coil housing assembly parts

Waterproof NEMA 4 coil housing option for the following normally open valve series:
3001, 4001, 5001, 6001, 8001, 15401, 15801, 16001

Note that there are some minor differences among housings used on these valves

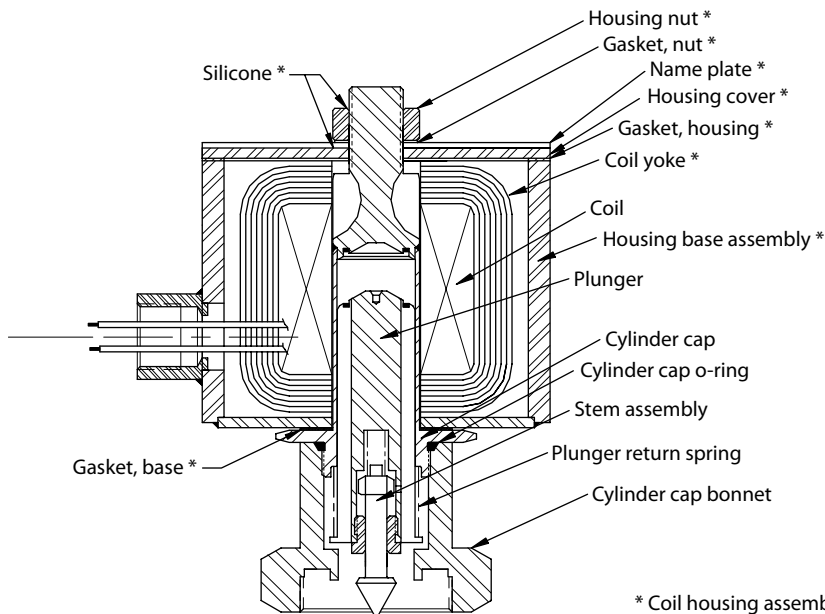

* Coil housing assembly parts

Waterproof NEMA 4 coil housing option for the following valve series:
13000, 30400, 30800, 35000, 40000, and 50000

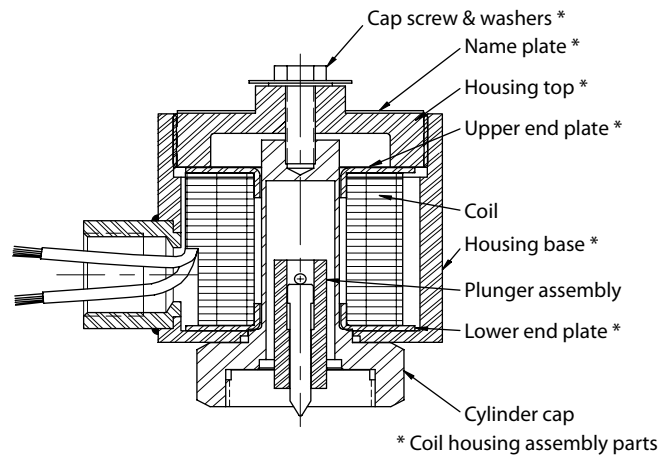

* Coil housing assembly parts

Explosion-proof NEMA 7 & 9 coil housing option for 500 valve series.

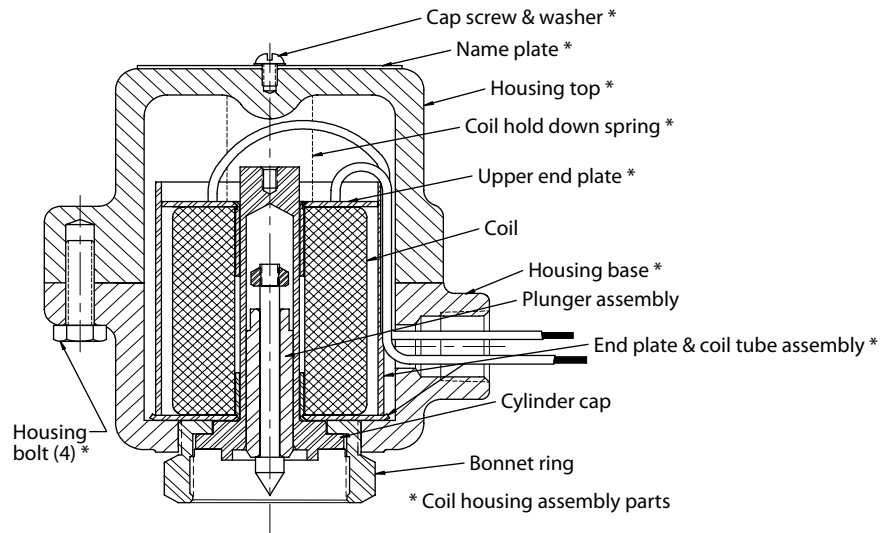

* Coil housing assembly parts

Explosion-proof NEMA 7 & 9 coil housing option for the following valve series:
2000, 3000, 4000, 5000, 6000, 7000, 8000, 15400, 15800, 16000

There are some differences among housings used on these valves. For instance, the 2000 Series housings do not use the 4 housing bolts and the housing top is threaded to the top of the cylinder cap. The cap screw & washer is also replaced with a nut that is threaded to the cylinder cap.

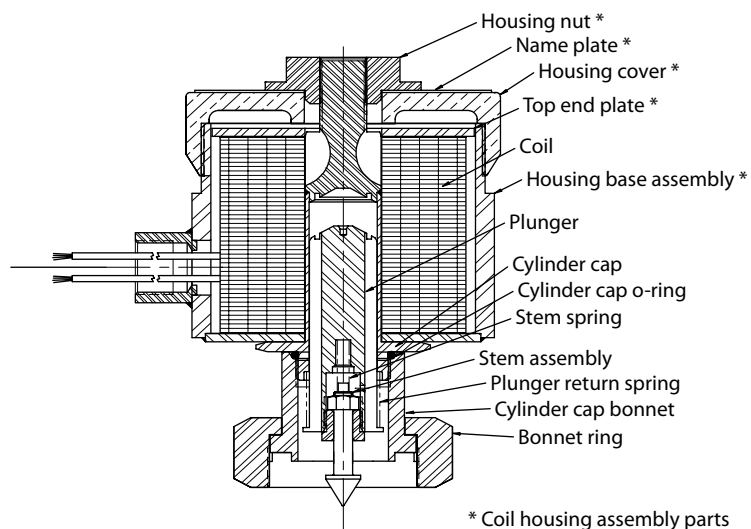

* Coil housing assembly parts

Explosion-proof NEMA 7 & 9 coil housing option (Shown with a DC coil) for the following valve series: 13000, 30400, 30800, 35000, 40000, and 50000

Note: These NEMA 7 housings are made into combination waterproof & explosion-proof NEMA 4 & 7 housings by the application of silicone sealant to the outside of the joints.

Coil Housings for Hazardous Locations

Explosion-proof coil housing on ATKOMATIC valves are NEMA 7 & 9 enclosures and meet the requirements for Division I, Class I, groups C & D.

The National Electrical Code defines various types of hazardous areas and classifies them by class, group, and division. The Code is maintained by the National Fire Protection Association and is recognized as the standard for electrical installations in the United States. Basically, class defines a distinction between types of explosive hazards in the atmosphere. Class I atmospheres contain hazardous vapors of volatile chemicals and class II atmospheres contain hazardous concentrations of dust or particulate that are potentially explosive. Each of these class designations is subdivided into groups that identify specific types of hazardous materials present. These are:

Class I group classifications:

Group A. Atmospheres containing acetylene

Group B. Atmospheres containing hydrogen or vapors of equivalent hazard such as butadiene, ethylene oxide, propylene oxide, and acrolein.

Group C. Atmospheres such as ethyl ether and ethylene.

Group D. Atmospheres such as acetone, ammonia, benzene, butane, cyclopropane, ethanol, gasoline, hexane, methanol, methane, natural gas, naphtha, and propane.

Class II group classifications:

Group E. Atmospheres containing combustible metal dusts including aluminum, magnesium, and their alloys.

Group F. Atmospheres containing combustible carbonaceous dusts including carbon black, charcoal, and coal.

Group G. Atmospheres containing other combustible dusts including flour, grain, wood, or plastics.

Industrial facilities are divided into two Divisions as follows:

Division I. These are areas where any of the hazardous atmospheres as defined above are present in the normal operation. For solenoid enclosures, this requires a housing that meets the requirements of NEMA 7 or 9.

Division II. These are areas where either:

- 1 Where volatile and flammable liquids or gases are handled and processed but where the vapors are confined within closed containers or systems from which they can only escape in case of accidental rupture or breakdown.
- 2 Where ignitable concentrations of vapors are prevented by mechanical ventilation.

For solenoids, explosion-proof NEMA 7 or 9 enclosures are not required by the National Electric Code for these Division II locations.

The National Electrical Manufacturers Association (NEMA) defines physical requirements of solenoid enclosures for use in hazardous locations in NEMA standard # 250 (some of the requirements are in referenced Underwriters Laboratories standards ANSI/UL 698 or 1002).

Cv Flow Coefficients & Valve Sizing

The flow coefficient, Cv, is the volume (in gallons) of water at 60° F that will flow per minute through a valve with a pressure drop of 1 psi across the valve. Numerically this definition can be expressed as:

$$Cv = F \div \sqrt{\Delta P}$$

The use of the flow coefficient offers a standard method of comparing valve capacities and sizing valves for specific applications that is widely accepted by industry. The general definition of the flow coefficient can be expanded into equations modeling the flow of liquids, gases and steam as follows:

Liquid flow

$$F = Cv\sqrt{\Delta P \div S} \quad Cv = F \div \sqrt{(\Delta P \div S)} \quad \Delta P = S (F \div Cv)^2$$

Gas flow

When the downstream pressure (P₂) is greater than 53% of the inlet pressure (P₁), the following formulae apply:

$$F = 1,391 Cv \sqrt{(P_2 \Delta P \div S T)} \quad Cv = F \div 1,391 \sqrt{(P_2 \Delta P \div S T)} \quad \Delta P = S T (F \div 1,391 Cv)^2 \div P_2$$

When the downstream pressure is equal to or less than *53% of the inlet pressure (P₁), the following formulae apply:

$$F = 695.4 Cv P_1 \div \sqrt{S T} \quad Cv = F \sqrt{S T} \div 695.4 P_1 \quad P_1 = F \sqrt{S T} \div 695.4 Cv$$

Steam flow

When the downstream pressure (P₂) is greater than 57% of the inlet pressure (P₁), the following formulae apply:

$$F = 3 Cv \sqrt{(P_2 \Delta P \div X)} \quad Cv = F \div 3 \sqrt{(P_2 \Delta P \div X)} \quad \Delta P = X (F \div 3 Cv)^2 \div P_2$$

When the downstream pressure (P₂) is equal to or less than 57% of the inlet pressure (P₁), the following formulae apply:

$$F = 3 Cv P_1 \div 2 \sqrt{X} \quad Cv = 2 F \sqrt{X} \div 3 P_1 \quad P_1 = 2 F \sqrt{X} \div 3 Cv$$

Note: Equations are for saturated steam

Definitions

Cv	Flow coefficient or flow capacity rating of valve
F	Rate of flow in USGPM for liquids, SCFH for gases, and lbs/hr for steam.
T	Absolute temperature in degrees Rankine (°R) (460 + degrees Fahrenheit(°F))
S	Specific gravity (relative to air or water)
P ₁	Inlet pressure, PSIA
P ₂	Downstream pressure, PSIA
ΔP	Pressure drop across the valve, PSI
X	Quality of steam in decimal form. i.e. 80% quality = 0.80
USGPM	U.S. gallons per minute
SCFH	Standard cubic feet per hour
PSI	Pounds per square inch
PSIA	Pounds per square inch absolute (PSIA = PSI + 14.7)

* The 53% is accurate for air, nitrogen, hydrogen, and oxygen. The values for other fluids will vary slightly. For instance: helium and argon 49%, methane and carbon dioxide 55%.

Cv Flow Coefficient Chart for ATKOMATIC Valves

VALVE ORIFICE SIZE	ANGLE TYPE VALVE: BARSTOCK BODY			GLOBE TYPE VALVE: CAST BODY					
	1000 2000 50000	7004	14000	JJ HS 500 15400	4000 5000 6000 30400	3000	12000	8000 15800 30800	16000
1/32"	0.020	—	—	—	—	—	—	—	—
3/64"	0.056	—	—	—	—	—	—	—	—
1/16"	0.093	—	0.093	—	—	0.093	—	—	0.093
3/32"	0.22	—	0.22	—	—	0.22	—	—	0.22
1/8"	0.44	—	0.40	—	—	0.44	—	—	0.44
5/32"	—	—	—	—	—	—	—	—	—
3/16"	0.72	—	—	—	—	0.72	—	—	0.72
7/32"	—	—	—	—	—	—	—	—	—
1/4"	—	1.0	—	1.4	1.4	—	—	1.1	—
3/8"	—	2.0	—	2.7	2.7	—	2.8	2.5	—
1/2"	—	2.0	—	3.5	3.5	—	4.2	5.1	—
3/4"	—	—	—	7.5	8.4	—	8.5	7.5	—
1"	—	—	—	9.1	9.5	—	8.9	12.5	—
1 1/4"	—	—	—	19.5	19.5	—	—	21.0	—
1 1/2"	—	—	—	21.0	21.0	—	—	21.5	—
2"	—	—	—	46.0	43.0	—	—	45	—
2 1/2"	—	—	—	—	63.0	—	—	—	—
3"	—	—	—	—	71.0	—	—	—	—

Factory Leakage Standards

Gas Internal Leakage Standard

Pilot Operated & Semi-direct Lift Valves

SEAT MATERIAL	TEST PRESSURE, psig					
	1-25	26-100	101-500	501-1,500	1,501-3,000	OVER 3,000
Rubber pilot & disc	B.T.	B.T.	B.T.	B.T.	B.T.	B.T.

For 500 and 15400 valve Series, both N.O. and N.C.

SEAT MATERIAL	TEST PRESSURE, psig					
	1-25	26-100	101-500	501-1,500	1,501-3,000	OVER 3,000
Teflon® pilot & Teflon® disc	500 sccm	100 sccm	B.T.	B.T.	B.T.	B.T.

For 4000, 5000, 6000, 7000, 8000, 12000, 15800, and 30000 valve Series, both N.O. and N.C.

SEAT MATERIAL	TEST PRESSURE, psig					
	1-25	26-100	101-500	501-1,500	1,501-3,000	OVER 3,000
Teflon® pilot & Teflon® disc	200 sccm	*	B.T.	B.T.	B.T.	B.T.
Metal pilot & Teflon®/Kel-F®/rubber disc	1,500 sccm	1,500 sccm	1,000 sccm	500 sccm	500 sccm	500 sccm
Metal pilot & metal disc	2,000 sccm	2,000 sccm	3,000 sccm	3,000 sccm	3,000 sccm	3,000 sccm
Kel-F® pilot & Kel-F® disc	500 sccm	250 sccm	100 sccm	10 sccm	B.T.	B.T.

Direct Lift Valves

SEAT MATERIAL	TEST PRESSURE, psig					
	1-25	26-100	101-500	501-1,500	1,501-3,000	OVER 3,000
Rubber seat	B.T.	B.T.	B.T.	B.T.	B.T.	B.T.
Plastic seat	50 sccm	5 sccm	B.T.	B.T.	B.T.	B.T.
Metal seat	1,000 sccm	1,000 sccm	1,500 sccm	1,500 sccm	1,500 sccm	1,500 sccm

* 26-50 psig = 50 sccm; 51-100 psig = 10 sccm

Liquid Internal Leakage Standard

Pilot Operated & Semi-direct Lift Valves

SEAT MATERIAL	TEST PRESSURE, psig					
	1-25	26-100	101-500	501-1,500	1,501-3,000	OVER 3,000
Rubber Pilot & Disc	0	0	0	0	0	0
Teflon® Pilot & Teflon® Disc	5 cc/m	*	0	0	0	0
Metal Pilot & Teflon®/Kel-F®/Rubber Disc	5 cc/m	5 cc/m	5 cc/m	5 cc/m	5 cc/m	5 cc/m
Metal Pilot & Metal Disc	10 cc/m	10 cc/m	10 cc/m	10 cc/m	10 cc/m	10 cc/m
Kel-F® Pilot & Kel-F® Disc	5 cc/m	5 cc/m	0	0	0	0

Direct Lift Valves

SEAT MATERIAL	TEST PRESSURE, psig					
	1-25	26-100	101-500	501-1,500	1,501-3,000	OVER 3,000
Rubber Seat	0	0	0	0	0	0
Plastic Seat	2½ cc/m	**	0	0	0	0
Metal Seat	5 cc/m	5 cc/m	5 cc/m	5 cc/m	5 cc/m	5 cc/m

* 26-75 psig = 5 cc/m; 75-100 psig = 0 cc/m

** 26-75 psig = 2½ cc/m; 75-100 psig = 0 cc/m

Definitions

Rubber	Elastomer (Buna N, Viton®, EPR, etc.)
B.T.	Bubble tight (less than 10 cc/hr leakage)
0	No leakage visible to the naked eye
sccm	Standard cubic centimeters per minute
cc/m	Cubic centimeters per minute

Note: Leakage values with Teflon® and Kel-F® seats are after applicable after the valve has been cycled in production acceptance testing. Typically on clean fluid applications with Teflon® or Kel-F® seats leakage decreases with number of cycles.

Response Times

Solenoid valves are relatively quick operating compared to other types of valves against which they compete. Most open and close operations occur in fractions of a second. This compares to seconds that valves such as motor operated ball valves require. Generally speaking, solenoid valves will respond much more rapidly on a gas, particularly a low molecular weight gas, than a liquid. Liquids, due to their resistance to compression, much completely displace around a plunger or piston that is traveling through the media. In a solenoid valve this frequently means that as a piston strokes, the volume of fluid that it displaces must pass through the pilot orifice or through the sum of the bleed orifice and piston ring gap(s). This takes a relatively long length of time particularly at low pressure drops. Liquids of high viscosity such as hydraulic oils will dampen motions of parts in valves and result in slowed opening and closing times than valves used on lower viscosity fluid such as gasoline or liquid nitrogen.

When a solenoid is first energized there is a time delay caused by inductance which opposes the immediate build-up of current and delays the formation of the magnetic field. This time delay is small compared to the motions of the valve components. Motions of components in a solenoid valve can be divided into two distinct categories: 1) the motion of the plunger or plunger/stem assembly (in a direct lift valve this is the only valve unit motion), and 2) motion of the piston as it strokes through its travel. The plunger motion is relatively quick, typically occurring in a matter of tens of milliseconds. The motion of the piston is relatively much slower for the reasons given in the preceding paragraph. Times for the piston motion can range in the low hundreds of milliseconds for opening depending on valve size, fluid pressure, and viscosity. Times for closing can range from a few hundred milliseconds on up depending on valve size, pressure drop across the valve caused by fluid flow, and fluid viscosity. For large valves in the 2 to 3" range on liquids at low flow rates, closing times can be several seconds.

The 35000 Series valve was designed for rapid closing and has been tested for opening and closing times with several sizes on both air and water. It utilizes an external pilot, which produces a faster closing response than internally piloted valves. Opening times of 150 milliseconds and closing times of 100 milliseconds have been measured with several sizes on applications with gaseous media and pressure drops of 500 to 1,000 psid across the valves.

A valve's response time is fixed for a given application, i.e. there are no adjustments that affect the response time.

Quantitative response time data has not been generated for most of the ATKOMATIC valve line, consult the Sales Department at the factory for the availability of testing.

Life Cycle Capability

ATKOMATIC valves are a rugged and robust product that are designed to serve a wide variety of demanding applications in markets including turbine manufacturing, chemical process, electric and gas utilities, industrial gasses, metal fabrication, food processing, oil refining, cryogenic transfer, and heating and air conditioning. Within these applications there is a vast diversity of fluid types, concentrations, degree of contamination, operating pressures, fluid and ambient temperatures, coil voltages, electrical enclosure types, cycle rates, valve types and sizes. This makes it impractical to establish any meaningful estimates of product lifetime or number of cycles that can be generally expected. This also causes the results of any testing conducted to be applicable to one specific or a very limited number of applications. Due to the limited usefulness of such testing and the expense associated with running life cycle testing over a long period of time the factory has not conducted testing to determine life cycle capability for particular applications. Additionally it has never been economically attractive for a customer to fund such a program. In all cases where life cycle capability has been a question trials in the field using the product in the application has been the preferred method of determining product duration.

In some applications, such as oil at ambient temperature, modest pressures, and low cycle rates, valves have lasted for millions of cycles and for dozens of years without difficulty. In other applications with dry gasses and high cycle rates, valves can wear after a matter of days and thousands or hundreds of thousands of cycles. Generally, liquids providing lubrication and dampening of motion will allow more extended cycle life than a dry gas. Corrosive fluids and higher temperatures both act to reduce cycle life. Certain types of applications that are known to be extremely severe, such as continuous and very rapid cycle rates with non-lubricated air, will result in very limited valve life expectancy.

Many demanding applications are handled satisfactorily with periodic maintenance involving inspection and/or replacement of internal parts. Appropriate maintenance intervals are determined by field experience on an individual application basis. Standard repair kits that contain all parts subject to wear are available for all the valve series (see page 3). For the most demanding applications, high cycle plunger assemblies are also available for most valve series (see page 86).

UL & CSA Listings and Approvals

Underwriters Laboratories

General Purpose Catalog Valves

FILE NUMBER	CATALOG BASE NO.	SIZE	FLUID, PRESSURE, VOLTAGE (SAME FOR ALL OF GROUP)
4000 & 5000 SERIES GROUP			
MH11913	4008	¼" NPT	Air, water, oil: 5 to 500 psig, fluid temp. to 66° C (151° F) (5 to 300 psig for 5708) Saturated steam: 5 to 200 psig Voltages: 120 VAC, 60 Hz; 240 VAC, 60 Hz; 480 VAC, 60 Hz Ambient temperature: 25° C (77° F)
	4108	⅜" NPT	
	4208	½" NPT	
	4308	¾" NPT	
	4408	1" NPT	
	4508	1¼" NPT	
	4608	1½" NPT	
5708	2" NPT		
15000 SERIES			
MH11913	15408	¼" NPT	Air, water, oil: 0 to 300 psig, fluid temp. to 66° C (151° F) Saturated steam: 0 to 125 psig Voltages: 120 VAC, 60 Hz; 240 VAC, 60 Hz; 480 VAC, 60 Hz Ambient temperature: 25° C (77° F)
	15418	⅜" NPT	
	15428	½" NPT	
	15438	¾" NPT	
	15448	1" NPT	

Specific Usage Project Valve

FILE NUMBER	PROJECT VALVE MODEL NUMBER	FLUID, PRESSURE, VOLTAGE (SAME FOR ALL OF GROUP)
E104727	31820-436	Class I, Group B hazardous locations, General Purpose Liquid hydrogen: 0 to 250 psig Fluid temperature: -252° C (-422° F) Voltage: 115 VAC, 60 Hz Ambient temperature: -40° to +40° C (-40° F to 104° F)

Catalog Numbers for UL Listed Valves

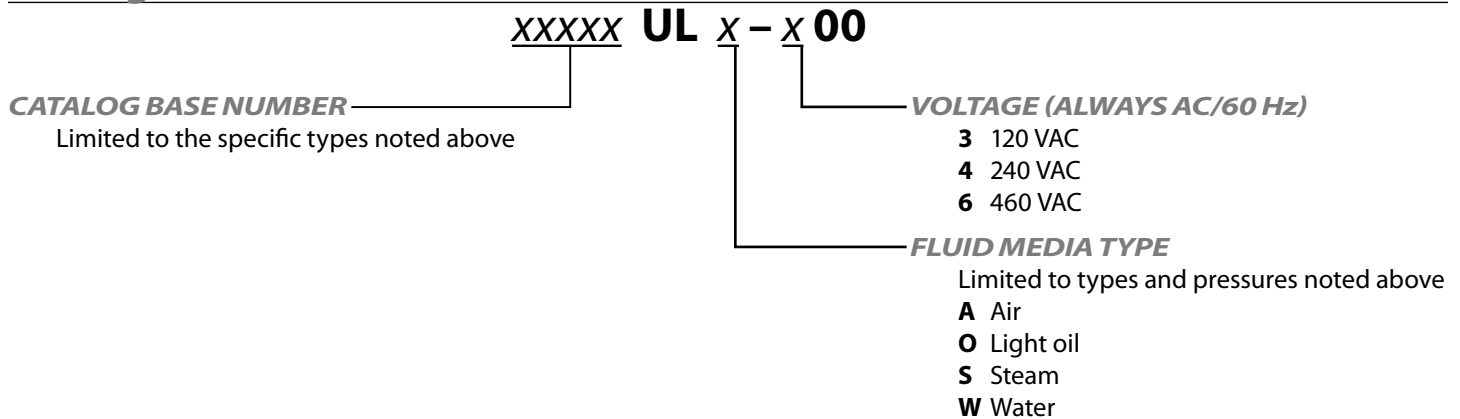

Canadian Standards Association

REPORT NUMBER	PROJECT VALVE MODEL NUMBER	FLUID, PRESSURE, VOLTAGE (SAME FOR ALL OF GROUP)
LR80415-3	35871-691	Natural gas, 2" flanges, 400 to 600 psig, 24 VDC, 40° C (104° F) ambient
	31830-706	Oil, ¾" NPT, 0 to 100 psig, 24 VDC, 40° C (104° F) ambient
	31861-697	Oil, 1½" NPT, 0 to 1,000 psig, 24 VDC, 40° C (104° F) ambient
	32820-714	Natural gas, ½" NPT, 0 to 1,500 psig, 24 VDC, 40° C (104° F) ambient
	2100-707	Natural gas, ¼" NPT, 0 to 1,000 psig, 24 VDC, 40° C (104° F) ambient
	35840-937	#2 Diesel, 1" Flanges, 0 to 950 psig, 24 VDC, 60° C (104° F) ambient All are class 3228 01 for Hazardous Locations Class I, Group D, General Purpose Valves

In addition to these CSA approvals on specific valves, Special Acceptances from CSA are available on the explosion-proof coil housing assemblies using 24 VDC coils only on the following series of valves:

- 13000 ¼" through ½", distributor, normally open, and normally closed, stainless
- 30400 ¼" through 3" N.C. and ¼" through 1½" N.O., bronze
- 30800 ¼" through 2" N.C. and ¼" through 1½" N.O., stainless
- 35800 ¾" through 3", normally open and closed, stainless
- 40800 ¼" through 1½", normally open and closed, stainless
- 50000 ⅛" through 1", normally open and closed (formally 13800 & 13900), stainless

Position Indicator Switch Adjustment

1 Explosion-proof NEMA 7 housings:

Unscrew the housing cover from the base and valve body assembly by using a strap wrench on the aluminum housing cover. The 2 switches and mounting block are now exposed.

Waterproof NEMA 4 and standard NEMA 1 housings:

Unscrew the housing screw at the center of the housing bottom and remove the housing. The 2 switches and mounting block are now exposed.

WARNING: Do not allow the weight of the housing cover to pull on the switch leads. This can permanently damage the switches.

Note: It is recommended that the following steps be performed with an ohmmeter connected directly to the lead wires of the position switches and the coil and cylinder cap removed so that the piston can be manually moved.

2 With the valve in the closed position, loosen the Closed Switch Adjustment Set Screw and gently slide the Closed Position Switch either up or down in the mounting block until the switch closes.

3 Move the piston up from the closed position and verify that the switch opens before the piston reaches the full open position.

4 Adjust the position of the switch as required until the conditions of steps 3 and 4 are met.

Note: The position of the switches will vary from valve to valve as the exact position of the reed switch within the switch tube is subject to variation.

Note: The switches can also be rotated in the mounting block. This can affect their sensitivity and in some cases aid in setting of the switches. Again, this is because there is variation in the position of the reed switch within the tube.

5 Tighten the Closed Switch Adjustment Set Screw.

6 With the valve in the open position, loosen the Open Switch Adjustment Set Screw and gently slide the Open Position Switch either up or down in the mounting block until the switch closes.

7 Move the piston down from the open position and verify that the switch opens before the piston reaches the fully closed position.

8 Adjust the position of the switch as required until the conditions of steps 6 and 7 are met.

9 Tighten the Open Switch Adjustment Set Screw.

10 Repeat the test of the switches with the valve assembled, the valves position controlled by energizing the coil, and with full system pressure. Repeat the above steps as required.

Note: There are 2 set screws in the center of the plastic mounting block that hold the block to the magnet tube. Generally it is not necessary to loosen these set screws and adjust the position of the block relative to the magnet tube. If necessary to achieve switch positioning this can be done.

11 Replace the housing cover.

See page 85 for a drawing of the position indicator switch assembly.

Aligning Coil Housings

Some valves use cast iron explosion-proof housings that are threaded directly to the valve body bonnets. This means that the angular position of the conduit fitting will be random when the housing is tightened down. These NEMA 7 housings are used on the following valve series:

2000, 3000, 4000, 5000, 6000, 7000, 8000, 12000 (DC only), 14000 (DC only), 15000, and 16000

When an explosion-proof housing is ordered on any of these valves, a set of 4 shims is included with the valve. The part number for this shim kit is 61427 (Atko p/n 229). If the angular alignment of the coil housing is not important the installation of the shims is not required.

Instructions for Installing Shims

1 Unscrew the cast iron coil housing assembly from the valves bonnet or cylinder cap.

Note: If holding the valve in a vise, clamp on it either end to end or on the hex portion. Do NOT clamp across the width of the valve body. This can distort the valve body and prevent proper piston motion.

2 Place the shims over the cylinder cap tube so that they rest on the cylinder cap or bonnet.

3 Screw the cast iron coil housing back onto the bonnet or cylinder cap.

Note: There are 4 shims with thickness of 0.005, 0.010, 0.015, and 0.020. Use any combination of these that allow the coil housing thread to bottom out such that the conduit fitting is oriented in the desired direction.

4 Repeat steps 2 and 3 as required.

Note: Do not use more than 0.050 if shims (all those provided) or the explosion-proof feature of the housing will be compromised.

All other valves with any type of coil housing can be aligned by loosening the screw or nut at the top of the coil housing, rotating the housing, then re-tightening the screw.

Field Modifications

Coil Replacement

All ATKOMATIC valves are designed for easy coil replacement without removing the valve from the line. This involves removal of 1 to 4 fastener(s) and does not break into fluid containment

AC to DC conversion

This can be accomplished on most valves in the field by just changing coils with the following exceptions. The 13000, 30400, 30800, 35000, 40000, and 50000 Series valves require the installation of an endplate with the DC coil when converting from AC operation:

The 12000 and 14000 Series valves require the replacement of the complete coil housing assembly and the cylinder cap to switch from AC to DC or DC to AC operation. This conversion is not recommended for the field.

Note: Converting from AC to DC operation will usually result in lower operational pressures.

DC to AC conversion

This can be accomplished on some valves in the field. The following valves can be converted by just changing coils: HS, JJ, 1000, 2000, 7000, 15800, and 15-794. The following valves can be converted only in their normally closed configurations: 500, 3000, 4000, 5000, 6000, 8000, 15400, and 16000 Series.

The following valves require shading rings for AC service which can only be installed at the factory and cannot be converted to AC service in the field:

- 12000 & 14000 Series
- Normally open & closed 30400, 30800, 35800, 40800, and 50000 Series
- All versions of the 13000 Series
- Normally open 501, 3001, 4001, 5001, 6001, 8001, 15401, and 16001 Series.

For more detailed instructions on coil replacement see the Installation, operating, & troubleshooting instructions for the specific valve series. These are available from the factory, authorized distributors, and on the Internet at <http://www.circle-seal.com/atkomatic.html>.

Converting from normally closed to normally open & visa versa

This conversion is not recommended for the field. It is possible to do at the factory, however it is usually more economical to procure a new valve.

Converting valves to operate at a higher operational pressure and/or on a different fluid

This conversion is not recommended for the field. It is possible to do at the factory.

Adding or deleting position indicator, manual opening, or manual throttling options

This conversion is not recommended for the field. It is possible to do at the factory.

NOTE: All ATKOMATIC valves are built exclusively for the type of fluid and pressure indicated on the product nameplate. Attempted usage at higher pressures and/or different fluids can result in immediate or delayed valve malfunction (failure to open or close and/or leakage).

Valve Operation

Normally closed valves remain in the closed position when the coil is not energized or return to the closed position upon removal of voltage from the coil.

Normally open valves remain in the open position when the coil is de-energized or return to the open position upon removal of voltage from the coil.

1 Direct Lift Normally Closed

Opening

When voltage is applied across the coil leads a current is produced in the coil windings which generates a magnetic field. The magnetic field attracts the plunger and causes it to move toward the center of the coil or magnetic stop. Initially the plunger slides freely on the stem until it impacts the nut or shoulder at the end of the stem. The plunger's momentum is then transferred to the stem and the stem is lifted off the seat screw or bottom nut orifice thus initiating flow through the valve.

Closing

When voltage is removed from the coil leads, the magnetic field collapses. Gravity pulls both the plunger and stem down until the stem point seals off the orifice stopping flow through the valve.

2 Direct Lift Normally Open

Closing

When voltage is applied across the coil leads a current is produced in the coil windings which generates a magnetic field. The magnetic field attracts the plunger and causes it to move toward the center of the coil or magnetic stop, compressing the plunger return spring as it travels. The plunger assembly continues to move until the stem shuts off the valve orifice stopping flow through the valve.

Opening

When voltage is removed from the coil leads, the magnetic field collapses. The force exerted by the compressed plunger return spring then pushes the plunger up from its position at the center of the coil or adjacent to the magnetic stop. Initially the plunger slides freely on the stem until it impacts the nut or shoulder at the end of the stem. The plunger's momentum is then transferred to the stem and the stem is lifted off the seat screw or bottom nut orifice thus initiating flow through the valve.

The following types of valves have magnetic stops that the plunger is held against when the valve is actuated: 500 N.O., 12000, 13000, 14000, 15400 N.O., 30400 N.O. & N.C., 30800 N.O. & N.C., 35000 N.O. & N.C., 40000 N.O. & N.C., 50000 N.O. & N.C.. Shading rings located on the magnetic pole faces are utilized in AC versions of these valves to minimize the chatter of the plunger against the magnetic stop. The changing magnetic field in the coil induces an electric current in the shading ring which in turn generated a secondary magnetic field which is out of phase with the coils magnetic field. This magnetic field generated by the shading ring is strong enough to hold the plunger against the magnetic stop during the time that the coil's magnetic field is at its minimum, thus preventing the chattering or AC hum. The stainless steel valves use silver (999 fine) ring(s) and the bronze valves use copper (electrical grade) ring(s).

3 Pilot Operated Normally Closed

Opening

When voltage is applied across the coil leads a current is produced in the coil windings which generates a magnetic field. The magnetic field attracts the plunger and causes it to move toward the center of the coil or magnetic stop. Initially the plunger slides freely on the stem until it impacts the nut or shoulder at the end of the stem. The plunger's momentum is then transferred to the stem and the stem is lifted off the seat screw pilot orifice. Fluid from the cavity above the piston flows through the pilot orifice in the seat screw and through the drilled hole in the center of the piston to the downstream side of the valve. Pressure above the piston decreases since the pilot orifice is larger in diameter than the bleed orifice. Inlet pressure acting around the annular area outside of the main valve seat at the bottom of the piston then pushes the piston up, thus initiating flow through the valve.

Note that flow through the valve creating a pressure drop across the valve is required to hold the piston open. If flow is diminished the piston will move toward the closed position. To maintain the valve fully open a pressure drop of 3 to 5 psid across the valve is required.

Closing

When voltage is removed from the coil leads, the magnetic field collapses. Gravity pulls both the plunger and

stem down until the stem point seals off the pilot orifice. Fluid flow from the valve's inlet side through the bleed orifice in the piston charges the cavity above the piston to a pressure equal to the valve's inlet pressure. Since downstream pressure is acting against the center portion of the bottom of the piston, the pressure forces acting on the piston are unbalanced and act to push the piston to the closed position (gravity and, with some valves, a piston spring assists in the closing).

It is characteristic for pilot operated valves to briefly open if subjected to a shock or sudden surge of inlet pressure. This is caused by the elevated inlet pressure pushing the piston open before the pressure above the piston can build via flow through the small bleed orifice. Once the pressure above the piston equalizes with the inlet pressure the valve closes.

4. Pilot Operated Normally Open

Closing

When voltage is applied across the coil leads a current is produced in the coil windings which generates a magnetic field. The magnetic field attracts the plunger and causes it to move toward the center of the coil or magnetic stop, compressing the plunger return spring as it travels. The plunger assembly continues to move until the stem shuts off the pilot orifice in the seat screw. Fluid flow from the valve's inlet side through the bleed orifice in the piston charges the cavity above the piston to a pressure equal to the valve's inlet pressure. Since downstream pressure is acting against the center portion of the bottom of the piston, the pressure forces acting on the piston are unbalanced and act to push the piston to the closed position (gravity assists in the closing).

Opening

When voltage is removed from the coil leads, the magnetic field collapses. The force exerted by the compressed plunger return spring then pushes the plunger up from its position at the center of the coil or adjacent to the magnetic stop. Initially the plunger slides freely on the stem until it impacts the nut or shoulder at the end of the stem. The plunger's momentum is then transferred to the stem and the stem is lifted off the pilot orifice in the seat screw, thus initiating flow through the pilot orifice in the seat screw. Fluid from the cavity above the piston flows through the pilot orifice in the seat screw and through the hole in the center of the piston to the downstream side of the valve. Pressure above the piston decreases since the pilot orifice is larger in diameter than the bleed orifice. Inlet pressure acting around the annular area outside of the main valve seat at the bottom of the piston then pushes the piston up, thus initiating flow through the valve.

Note that flow through the valve creating a pressure drop across the valve is required to hold the piston open. If flow is diminished the piston will move toward the closed position. To maintain the valve fully open a pressure drop of 3 to 5 psid across the valve is required.

5. Semi-direct Lift Normally Closed

Opening

When voltage is applied across the coil leads a current is produced in the coil windings which generates a magnetic field. The magnetic field attracts the plunger and causes it to move toward the center of the coil or magnetic stop. Initially the plunger slides freely on the stem until it impacts the nut or shoulder at the end of the stem. The plunger's momentum is then transferred to the stem and the stem is lifted off the seat screw orifice (This much of the action is identical to the pilot operated valves). The stem – plunger assembly continues its motion until the shoulder on the stem contacts the piston rod link. The piston rod link is attached to the piston, so as the stem – plunger assembly completes its motion, the piston is pulled from the main valve seat effecting the full opening of the valve. In actuality, the fluid force affects the motion of the piston at pressures above approximately 5 psig and the magnetic force on the plunger (through the mechanical connection of the stem to the plunger via the piston rod link) is sufficient to lift the piston at lower pressures.

Closing

When voltage is removed from the coil leads, the magnetic field collapses. Gravity pulls both the plunger and stem down until the stem point seals off the orifice in the piston rod link. Fluid flow from the valve's inlet side through the bleed orifice in the piston charges the cavity above the piston to a pressure equal to the valve's inlet pressure. Since downstream pressure is acting against the center portion of the bottom of the piston, the pressure forces acting on the piston are unbalanced and act to push the piston to the closed position (gravity and, in some valves, a piston spring assists in the closing).

Note: In this type of valve the piston opens and closes fully independent of line pressure or system flow.

It is characteristic for semi-direct lift valves to briefly open if subjected to a shock or sudden surge of inlet pressure. This is caused by the elevated inlet pressure pushing the piston open before the pressure above the piston can build via flow through the small bleed orifice. Once the pressure above the piston equalizes with the inlet pressure the valve closes.

6 Semi-direct Lift Normally Open

Opening

When voltage is removed from the coil leads, the magnetic field collapses. The force exerted by the compressed plunger return spring then pushes the plunger up from its position at the center of the coil or adjacent to the magnetic stop. Initially the plunger slides freely on the stem until it impacts the nut or shoulder at the end of the stem. The plunger's momentum is then transferred to the stem and the stem is lifted off the seat screw orifice (This much of the action is identical to the pilot operated valves). The stem – plunger assembly continues its motion until the shoulder on the stem contacts the piston rod link. The piston rod link is attached to the piston, so as the stem – plunger assembly completes its motion, the piston is pulled from the main valve seat effecting the full opening of the valve. In actuality, the fluid force effect the motion of the piston at pressures above approximately 5 psig and the magnetic force on the plunger (through the mechanical connection of the stem to the plunger via the piston rod link) is sufficient to lift the piston at lower pressures.

Closing

When voltage is applied across the coil leads a current is produced in the coil windings which generates a magnetic field. The magnetic field attracts the plunger and causes it to move toward the center of the coil or magnetic stop, compressing the plunger return spring as it travels. The plunger assembly continues to move until the stem shuts off the pilot orifice in the seat screw. Fluid flow from the valve's inlet side through the bleed orifice in the piston charges the cavity above the piston to a pressure equal to the valve's inlet pressure. Since downstream pressure is acting against the center portion of the bottom of the piston, the pressure forces acting on the piston are unbalanced and act to push the piston to the closed position (gravity assists in the closing).

Note: In this type of valve the piston opens and closes fully independent of line pressure or system flow.

7 13000 3-way Direct Lift

Normally Closed Valves

The inlet is the FNPT port on the bottom of the valve body. The normally closed port is on the side of the valve body. When the coil is energized flow is from the port on the bottom of the valve body to the port on the side of the valve body and the port at the top of the valve is closed off. When the coil is not energized there is no flow and the port on top of the valve is open to the port on the side of the valve body.

Normally Open Valves

The inlet is the ¼" MNPT port at the top of the valve (in the center of the nameplate). The normally open port is in the side of the valve body. When the coil is not energized, there is flow from the port on top of the valve to the port on the side of the valve body. When the coil is energized, the inlet port on top of the valve is closed off and the port on the side of the valve body is open to the port on the bottom of the valve.

Directional Flow Valves

The inlet is the FNPT port on the side of the valve body. When the coil is not energized, the inlet port is open to the port on top of the valve and the port at the bottom of the valve body is shut off. When the coil is energized the port at the top of the valve is shut off and the inlet port is open to the port at the bottom of the valve body.

The opening and closing operation is the same for each of the above three types of valves.

Opening

When voltage is applied across the coil leads a current is produced in the coil windings which generates a magnetic field. The magnetic field attracts the plunger and causes it to move toward the magnetic stop. Initially the plunger slides freely on the stem until it impacts the nut or shoulder at the end of the stem. The plunger's momentum is then transferred to the stem and the stem is lifted off the seat screw orifice. Plunger assembly motion continues until the top stem seals off the orifice at the top of the cylinder cap thus shutting it off.

Closing

When voltage is removed from the coil leads, the magnetic field collapses. Gravity and the plunger return spring pulls both the plunger and stem assembly down until the top stem opens the orifice at the top of the cylinder cap and the bottom stem seals off the orifice in the seat screw.

8 35000 Series Externally Piloted

These valves can be either normally open or normally closed depending on how the pilot is plumbed. There are also internal differences between normally open and normally closed valves.

The normally closed valve has the pilot inlet attached to the ¼" MNPT port at the top of the valve (in the center of the nameplate). The pilot exhaust port is the ¼" FNPT port in the side of the bonnet (the cylinder between the

valve body and coil housing).

The normally open valve has the pilot inlet plumbed to the ¼" FNPT port in the side of the bonnet (the cylinder between the valve body and coil housing). The pilot exhaust is the ¼" MNPT port at the top of the valve (in the center of the nameplate).

Opening

When voltage is applied across the coil leads a current is produced in the coil windings which generates a magnetic field. The magnetic field attracts the plunger and causes it to move toward the magnetic stop. Initially the plunger slides freely on the stem until it impacts the nut or shoulder at the end of the stem. The plunger's momentum is then transferred to the stem and the stem is lifted off the seat screw orifice. Plunger assembly motion continues until the top stem seals off the orifice at the top of the cylinder cap thus shutting off pilot flow. Pressure above the piston is bled off through drilled passageway in the bonnet and the seat screw to the pilot exhaust port. Inlet pressure acting around the annular area outside of the main valve seat at the bottom of the piston then pushes the piston up, thus initiating flow through the valve.

Closing

When voltage is removed from the coil leads, the magnetic field collapses. Gravity and the plunger return spring pulls both the plunger and stem assembly down until the top stem opens the orifice at the top of the cylinder cap and the bottom stem seals off the orifice in the stationary seat screw. Fluid flow from the pilot supply then flows directly into the cavity above the piston and charges this volume to a pressure equal to the valve's inlet pressure (assuming that the inlet pressure is being used as the pilot supply). Since the pilot pressure acts over the entire area of the piston and the downstream pressure is acting only against the center portion of the bottom of the piston, the pressure forces acting on the piston are unbalanced and act to push the piston to the closed position (gravity assists in the closing).

Note that the time to charge the volume above the piston and thus affect valve closure is considerably less than with flow through a bleed orifice in the piston as in other pilot operated valves.

With upstream line pressure used as source for pilot pressure the fastest closing times will be achieved when the maximum pressure drop is present across the valve. See page 75 for pilot plumbing and pressure requirements.



405 Centura Court
PO Box 4866 (29305)
Spartanburg, SC 29303
Tel (864) 574-7966
Fax (864) 587-5608

Circle Seal Controls, Inc.

2301 Wardlow Circle
PO Box 3300
Corona, CA 92880
Tel (951) 270-6200
Fax (951) 270-6201
www.circle-seal.com

GO Regulator

405 Centura Court
PO Box 4866 (29305)
Spartanburg, SC 29303
Tel (864) 574-7966
Fax (864) 587-5608
www.goreg.com

HOKE, Inc.

405 Centura Court
PO Box 4866
Spartanburg, SC 29303
Tel (864) 574-7966
Fax (864) 587-5608
www.hoke.com

CIRCOR Instrumentation, Ltd.

1-3 Bouverie Road
Harrow
Middlesex, HA1 4HB
UK
Tel +44 (0) 20 8423 0113
Fax +44 (0) 20 8864 7008
www.circor.co.uk

HOKE Controls

1901 Lynx Place
Ontario, CA 91761
Tel (909) 923-3770
Fax (909) 923-2550

Panels Plus

1901 Lynx Place
Ontario, CA 91761
Tel (909) 923-3770
Fax (909) 923-2550
www.circor-panelsplus.com

CIRCOR Tech

405 Centura Court
PO Box 4866 (29305)
Spartanburg, SC 29303
Tel (864) 574-7966
Fax (864) 587-5608
www.circortech.com

HOKE GmbH

Weitzesweg 11
Postfach 15 41
D-61118 Bad Vilbel-Dortelweil
Germany
Tel +49-6101-82 56 0
Fax +49-6101-82 54 0
www.hoke.de

TOMCO

51 Zima Park
PO Box 4866 (29305)
Spartanburg, SC 29303
Tel (864) 574-7966
Fax (864) 587-5608
www.tomcoquickcouplers.com

LIMITED WARRANTY

ALL CIRCLE SEAL CONTROLS, INC., GO REGULATOR, AND HOKE INC. PRODUCTS ARE MADE TO EXACTING STANDARDS OF DESIGN, MATERIAL, WORKMANSHIP AND QUALITY CONTROL AND ARE WARRANTED TO BE FREE OF DEFECTS IN MATERIAL AND WORKMANSHIP AND REASONABLY FIT FOR THE USES SET FORTH IN SELLER'S CATALOG OR THE CONTRACT SPECIFICATIONS FOR A PERIOD OF ONE YEAR AFTER SALE IF PROPERLY INSTALLED AND MAINTAINED AND UNDER THE NORMAL USE AND SERVICE FOR WHICH THE EQUIPMENT IS INTENDED. BUYER TO INSPECT THE GOODS WITHIN TEN DAYS OF DELIVERY AND TO THEN IMMEDIATELY NOTIFY SELLER OF ANY DEFECTS IN ORDER TO CLAIM A DEFECT. THIS WARRANTY IS IN LIEU OF ALL OTHER WARRANTIES WHETHER THEY ARE STATUTORY, EXPRESS OR IMPLIED, INCLUDING AMONG OTHER THINGS ANY IMPLIED WARRANTY OF MERCHANTABILITY FITNESS FOR A PARTICULAR PURCHASE NOT SET FORTH IN SELLER'S CATALOG, AND ALSO DOES NOT APPLY TO ANY PRODUCTS OF SELLER WHICH HAVE BEEN REPAIRED, ALTERED OR MODIFIED OR HAVE BEEN SUBJECT TO MISUSE OR ABUSE. SELLER IS NOT LIABLE FOR ANY CONSEQUENTIAL, INCIDENTAL OR SPECIAL DAMAGES RESULTING DIRECTLY OR INDIRECTLY FROM THE DESIGN, MATERIAL, WORKMANSHIP, OPERATION OR INSTALLATION OF ANY OF ITS PRODUCTS AND NEITHER ASSUMES NOR AUTHORIZES ANY OTHER PERSON TO ASSUME FOR IT ANY OTHER LIABILITY IN CONNECTION THEREWITH. BUYER'S EXCLUSIVE REMEDY SHALL BE THE REPAIR OR REPLACEMENT OF ANY SUCH DEFECTIVE PRODUCT AFTER VERIFICATION BY SELLER. THIS WARRANTY IS IN EFFECT UNLESS SUPERSEDED BY LIMITED WARRANTY, FORM NO. 2299 (4/83)