

BPR30 Series

*Corrosion Resistant Back Pressure Regulator
160 to 2,500 psig*



Features

- Positive shutoff at zero flow
- Compatible with corrosive or non-corrosive media
- Full range capability
- Unique design prevents clogging
- Tee handle for fast & precise control

Applications

- Compressors
- Pump bypass
- Hydrostatic testing
- Water descaling systems
- Pressure vessel protection
- Reverse osmosis systems

Technical Data

Body Construction Materials	Brass or 316 stainless steel
Seal Materials	Ethylene propylene, Neoprene, Teflon® or Viton®
Seat Material	Kel-F®
Trim Material	Stainless steel exposed to line fluids
Port Sizes	¼" or ½" NPT female
Weight	2.75 lbs
Pressure Ratings	160 to 2,500 psig (11 to 172 BAR)
Temperature Range	-65° F to +250° F (-54° C to +121° C)
Flow Capacity	Cv = 0.25

Note: Proper filtration is recommended to prevent damage to sealing surfaces.

How it Works

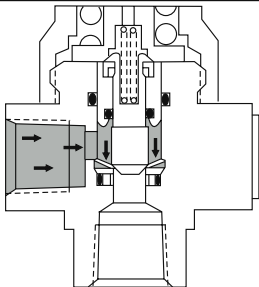

Closed

With the unit spring load adjusted to the desired regulated "set" pressure, a dead-tight seal is effected against the applied upstream pressure by the small seating spring contained within the poppet and spring retainer.

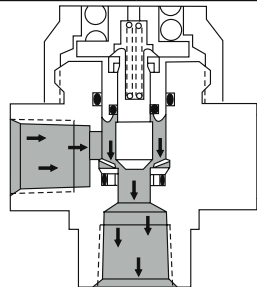

Regulating

When the upstream process pressure (acting on the regulating piston) increases, an opposing force is generated which, through the regulating piston, acts against the "set" spring load.

As the increasing upstream pressure level reaches the "set" pressure, the poppet is gradually lifted off its seat. A consequent decrease in upstream pressure is experienced when the flowing fluid is relieved to the downstream side of the poppet at a faster rate than the upstream pressure can supply.

With decreasing upstream pressure, the spring force starts the poppet moving toward its closed position, thus maintaining the desired "set" pressure level within a narrow band.

When the upstream pressure has decreased to a level just below "crack", the spring-loaded poppet again creates a tight seal against the sharp edge of the valve seat.

Circle Seal Controls

2301 Wardlow Circle • Corona, CA 92880
Phone (951) 270-6200 • Fax (951) 270-6201
www.circle-seal.com

back pressure regulators

BP-3 Series

Dimensions & Flow Curves

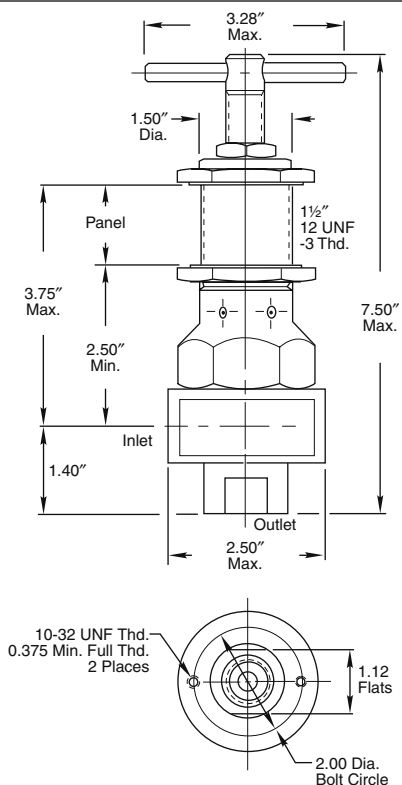

BPR30 Flow Chart

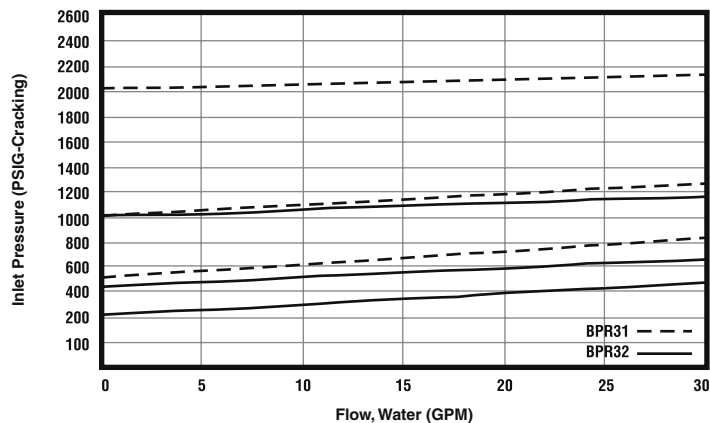

How to Order

K/ BPR32 B 2 1 2

REPAIR KIT

BASIC MODEL NUMBER

BPR32 160 to 1,000 psig (11 to 69 BAR)

BPR31 200 to 2,500 psig (14 to 172 BAR)

BODY MATERIALS

B Brass

U 316 stainless steel

INLET & OUTLET PORTS

1 1/4" NPT female

2 1/2" NPT female

CLEANING LEVELS*

1 General oxygen service

2 General pneumatic service

3 Specify (define on sales order)

SEAL MATERIAL

1 Neoprene

3 Viton®

4 Ethylene propylene

5 Teflon® (Viton® static seal is used under the seat with Teflon® piston seals)

These units are not intended for applications where the exhaust connection will see buildup of downstream pressure. If this regulator is to be used in oxygen service, Vespel® SP-21 seat and Viton® seal are used and specify "General Oxygen Service" when ordering. Temperature range: -20° F to +250° F.

Viton® static seal is used under the seat with Teflon® piston seals.

Please consult your Circle Seal Controls distributor, representative, or the factory for information on special connections, operating pressures and temperature ranges.

For Your Safety

It is solely the responsibility of the system designer and user to select products suitable for their specific application requirements and to ensure proper installation, operation, and maintenance of these products. Material compatibility, product ratings and application details should be considered in the selection. Improper selection or use of products described herein can cause personal injury or property damage.

Teflon® is a registered trademark of the DuPont Company.
 Viton® is a registered trademark of DuPont Dow Elastomers.
 Kel-F® is a registered trademark of 3M Company.