

GD30 Series

Inlet & Outlet 0–3,600 psig Dome-loaded Pressure Regulators

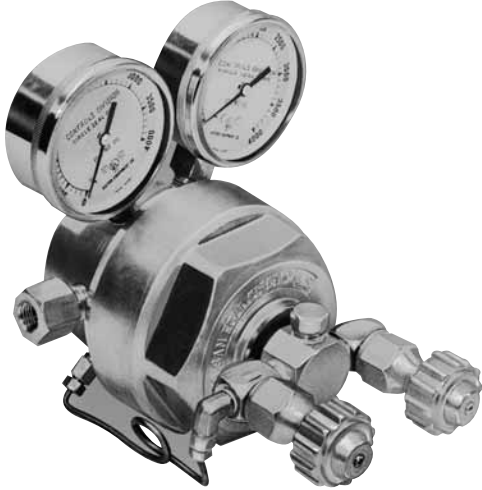

Features

- Bubble-tight seal
- Precise control
- Rapid delivery
- Easily adjusted

Applications

- Breathing systems
- Research laboratories
- Aircraft servicing
- Gas manifold systems
- Industrial gas plants
- Process gas control

Technical Data

Body Construction Material	Bronze
Seat Material	Neoprene
Seal Material	Copper
Diaphragm Material	Stainless steel
Gauge Material	Brass, 2½" diameter
Spring Material	Stainless steel
Port Sizes	<ul style="list-style-type: none"> • ¼", ½" pipe; AND10050–4 or –8 • Gauge ports: ¼" pipe • Dome-loaded ports: AS4395 (MS33656–4)
Pressure Rating	Inlet/Outlet: to 3,600 psig (248 BAR)
Temperature Range	–65° F to +160° F (–54° C to +71° C)
Flow Capacity	Cv = 0.35 Orifice diameter = 0.14"
Weight	<ul style="list-style-type: none"> • GD31 = 14.00 lbs • GD31R = 12.00 lbs

Note: Proper filtration is recommended to prevent damage to sealing surfaces.

How it Works

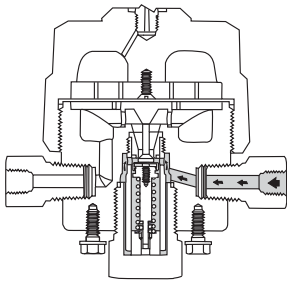

Closed

The unbalanced poppet is spring-loaded against the valve seat. Dead-tight sealing is ensured by a considerable force when full upstream pressure is applied over the entire effective area of the seating diameter.

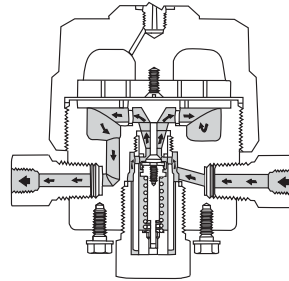

Regulating

Dome-loading may be accomplished by the built-in load and bleed valve combination (or by an externally located pressure regulator) depending upon the specific model used for the application.

As the downstream process demands flow, the decreasing pressure (acting on the outlet side of the diaphragm) allows the dome pressure force to push the diaphragm and lower plate down which, in turn, unseats the poppet.

The described action permits flow to start and the pressure under the piston to gradually increase until balance is achieved between dome pressure forces and opposing downstream pressure forces.

The modulation of the poppet position continues in this manner until process flow demand ceases. The diaphragm is then moved in an upward direction, thus allowing the spring-loaded poppet to close off flow from the upstream side of the regulator

Circle Seal Controls

2301 Wardlow Circle • Corona, CA 92880
 Phone (951) 270-6200 • Fax (951) 270-6201
 www.circle-seal.com

pressure regulators

GD30 Series

Dimensions & Flow Curves

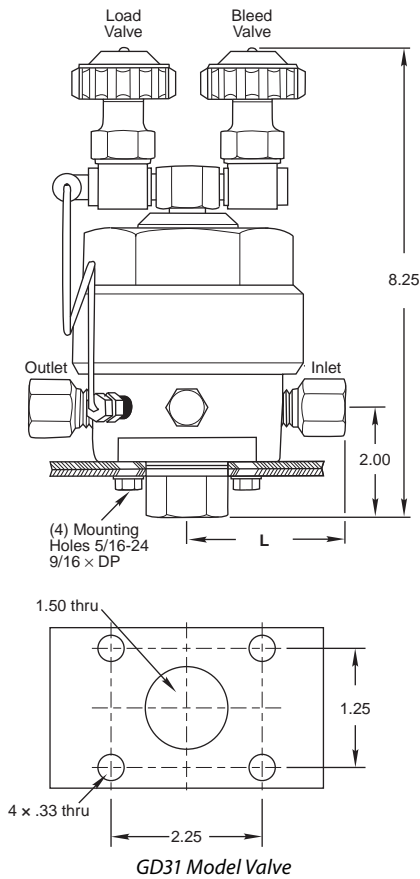

Connection	Dim. L
-1 AND10050-4	3.06
-2 AND10050-8	3.31
-3 1/4" NPT female	2.75
-4 1/2" NPT female	3.31

Air Flow Chart

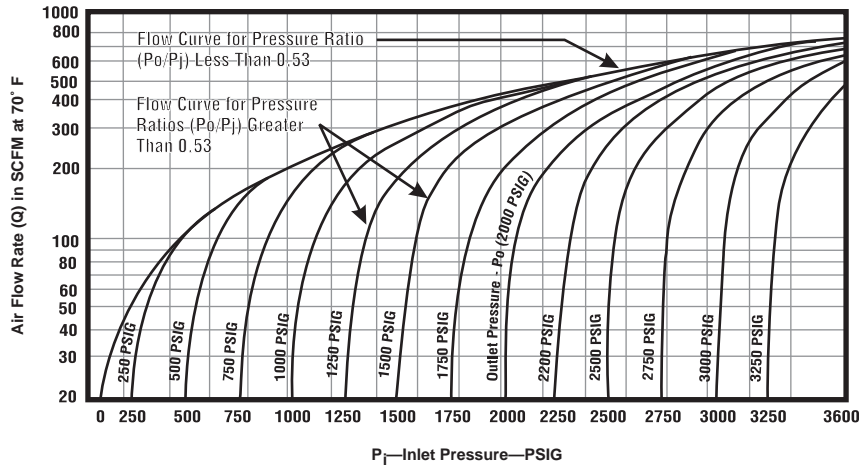

Correction factors for gases other than air:

Gas	Correction Factor
Air	1.000
Helium	2.690
Hydrogen	3.795
Nitrogen	1.016
Oxygen	0.951

Flow rates for gases other than air:

Air Flow Rate (Q) × correction factor

How to Order

K/ GD31 B 4 4 2 G

REPAIR KIT —————

BASIC MODEL NUMBER —————

GD31 Internal dome-loaded
GD31R Externally dome-loaded

BODY MATERIAL —————

B Bronze

INLET PORT —————

1 AND10050-4
2 AND10050-8
3 1/4" NPT female
4 1/2" NPT female

OPTIONS —————

G Gauges (0-5,000 psig)

CLEANING LEVELS —————

1 For general oxygen service*
2 For general pneumatic service
3 Specify (define on sales order)

OUTLET PORT —————

1 AND10050-4
2 AND10050-8
3 1/4" NPT female
4 1/2" NPT female

Outlet pressure changer per 100 psig inlet pressure change = 2.2 psi.

* Temperature range for oxygen service = -20° F to +250° F

Please consult your Circle Seal Controls distributor, representative, or the factory for information on special connections, operating pressures and temperature ranges.

For Your Safety

It is solely the responsibility of the system designer and user to select products suitable for their specific application requirements and to ensure proper installation, operation, and maintenance of these products. Material compatibility, product ratings and application details should be considered in the selection. Improper selection or use of products described herein can cause personal injury or property damage.