

GD90 Series

*Dynadome High Flow Dome-loaded Regulator
Inlet & Outlet to 6,000 psig*



Features

- High flow capacity
- Accurate pressure regulation
- Wide fluid compatibility

Applications

- High pressure testing
- Facility gas systems
- Industrial gas plants
- Process gas controls
- Bulk facility installations
- Gas turbine engine starter

Technical Data

Body Construction Material	Bronze
Seal & Diaphragm Material	Neoprene*
Seat Material	Nylatron**
Spring Material	Stainless steel
Port Sizes	Inlet & outlet: ¾", 1" & 1¼" NPT female, AND10050-12, -16, or -24
Pressure Ratings	Inlet/Outlet to 6,000 psig (414 BAR)
Temperature Range	-65° F to +160° F (-54° C to +71° C)
Flow Capacity	Cv = 5.0 Orifice diameter = 0.50"
Weight	Approx. 25 lbs

* Optional materials available, see "How to Order".

Note: Proper filtration is recommended to prevent damage to sealing surfaces.

How it Works

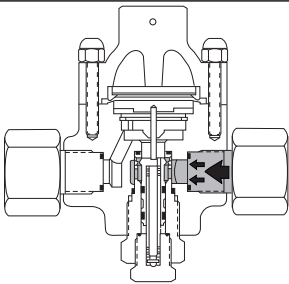

Closed

The balanced poppet is spring-loaded against the valve seat. When full upstream pressure is applied, a slight unbalanced force is developed which further enhances sealing.

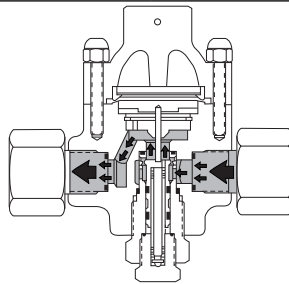

Regulating

Dome-loading may be accomplished by the load and bleed valve combination or by an externally located pressure regulator, depending on the specific model used for the application.

As the downstream process demands flow, the decreasing pressure (acting on the outlet side of the diaphragm) allows the dome pressure force to push the diaphragm and lower plate down which, in turn, unseats the poppet.

The described action permits flow to start and the pressure under the piston to gradually increase until balance is achieved between dome pressure forces and opposing downstream pressure forces.

The modulation of the poppet position continues in this manner until process flow demand ceases. The diaphragm is then moved in an upward direction, thus allowing the spring-loaded poppet to close off flow from the upstream side of the regulator.

Circle Seal Controls

2301 Wardlow Circle • Corona, CA 92880
Phone (951) 270-6200 • Fax (951) 270-6201
www.circle-seal.com

GD90 Series

How to Order

K/ GD91 B 1 1 1 1 1 M X

REPAIR KIT —————

BASIC MODEL NUMBER —————
GD91 Externally remote dome-loaded
GD92 Internally dome-loaded

BODY MATERIAL —————
B Bronze

INLET PORT TYPE & SIZE —————
1 AND10050-12
2 AND10050-16
3 AND10050-24
4 3/4" NPT female
5 1" NPT female
6 1 1/4" NPT female

OUTLET PORT TYPE & SIZE —————
1 AND10050-12
2 AND10050-16
3 AND10050-24
4 3/4" NPT female
5 1" NPT female
6 1 1/4" NPT female

OPTIONS
M Extended bolts for mounting
X Downstream sensing

CLEANING LEVELS
1 For general oxygen service*
2 For general pneumatic service
3 Specify (define on sales order)
4 Precision pneumatic service

SEAT MATERIAL
1 Nylatron® GS (standard)
2 Kel-F®**
3 Polyimide (VespeI®)

SEAL MATERIAL
1 Neoprene (standard)
2 EPR
3 Viton®
4 Buna N

* For oxygen service, use VespeI® seat; seal and diaphragm to be Viton® only
 ** Kel-F® seat: inlet & outlet pressures limited to 3,000 psig

Dome-loading ports are AND10050-4 with tube fittings and 1/4" NPT female with pipe on inlet and outlet fittings.
 Outlet pressure change rate: 0.10 psi per 100 psi inlet pressure change

Please consult your Circle Seal Controls distributor, representative, or the factory for information on special connections, operating pressures and temperature ranges.

Flow Curves & Dimensions

Air Flow Chart

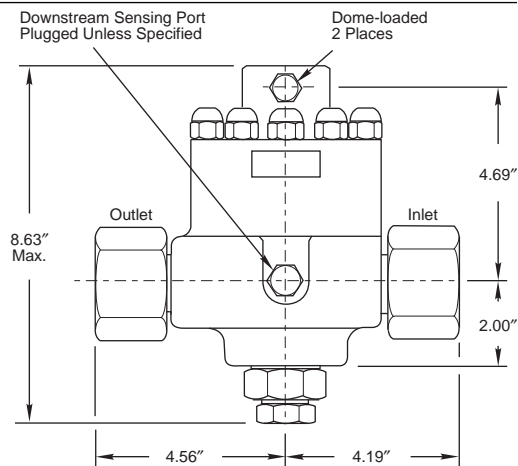
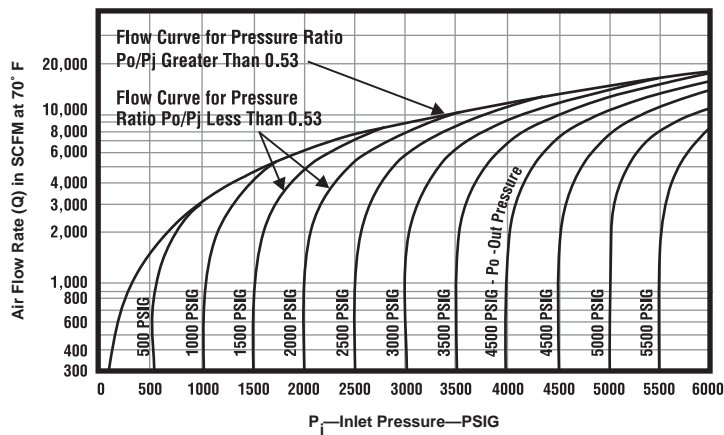

Correction factors for gases other than air:

Gas	Correction Factor
Air	1.000
Helium	2.690
Hydrogen	3.795
Nitrogen	1.016
Oxygen	0.951

Flow rates for gases other than air:

Air Flow Rate (Q) × correction factor

Nylatron® is a registered trademark of DSM Engineering Plastic Products.
 Kel-F® is a registered trademark of 3M Company.
 VespeI® is a registered trademark of E.I. du Pont de Nemours and Company.
 Viton® is a registered trademark of DuPont Dow Elastomers.

For Your Safety

It is solely the responsibility of the system designer and user to select products suitable for their specific application requirements and to ensure proper installation, operation, and maintenance of these products. Material compatibility, product ratings and application details should be considered in the selection. Improper selection or use of products described herein can cause personal injury or property damage.