

# HPR50 Series

*High Pressure, High Flow, Fluid Pressure Regulator  
Inlet 0 to 10,000 psig & Outlet 40 to 10,000 psig*



## Features

- Balanced poppet design
- Metal-to-metal seating
- Captured self-venting
- 303 or 316 stainless steel, or brass body
- High pressure 0–10,000 psig inlet and outlet range
- High flow equal to Cv of 0.30
- Internal damper for surge flows
- Ryton™ 7 plastic handle

## Applications

- Hydraulic test systems—high pressure
- Off-shore platforms—valve actuation
- Deep water drilling—hydraulic support
- Manufacturing processes

## Technical Data

<b>Body Construction Materials</b>	303 or 316 stainless steel, or brass construction
<b>Seat Material</b>	17-4 PH CRES
<b>Port Sizes</b>	¼" and ½" NPT female, ½" tube, or ½" BSPP
<b>Pressure Ratings</b>	Inlet: • CRES: to 10,000 psig (690 BAR) • Brass: to 6,000 psig (414 BAR) Outlet: 40 to 10,000 psig (2.7 to 690 BAR)
<b>Temperature Range</b>	–40° F to +225° F (–40° C to +107° C)
<b>Flow Capacity</b>	Cv = 0.30

*Note: Proper filtration is recommended to prevent damage to sealing surfaces.*

## How it Works

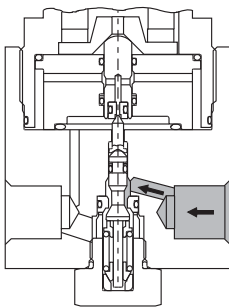

### Closed

The balanced poppet is spring-loaded against the seat.

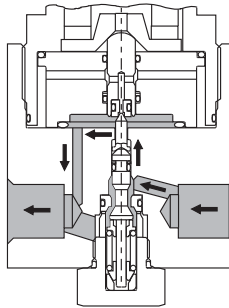

### Regulating

As the downstream process demands flow, the pressure acting on the piston decays, allowing the adjusting spring force to push the piston down, at which point increasing pressure overcomes spring force, moving the piston up and allowing the poppet to close.

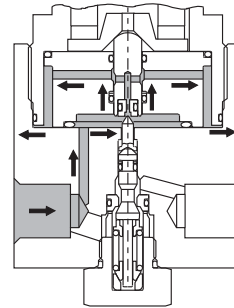

### Venting

If the downstream pressure should increase beyond regulation set point or the handle is backed off to decrease the regulated pressure level, the downstream pressure will vent through the piston and the guide to the vent port.

## Circle Seal Controls

2301 Wardlow Circle • Corona, CA 92880  
Phone (951) 270-6200 • Fax (951) 270-6201  
www.circle-seal.com

# HPR50 Series

## Dimensions, Gauges & Typical Flow Curves

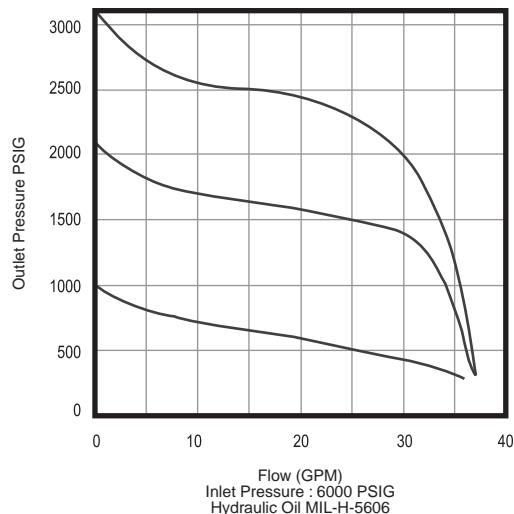
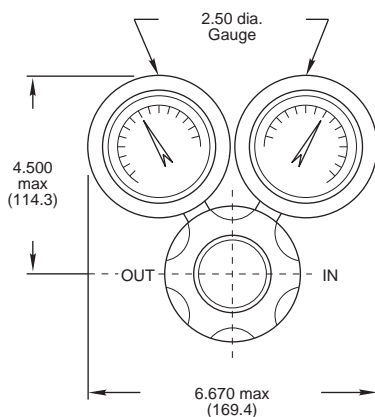
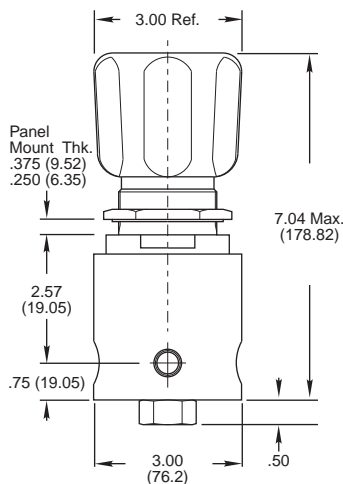

## How to Order

**K/ HPR5 0 T 1 1 N**

### REPAIR KIT

### OUTLET PRESSURE RANGE

- 0** 150 to 1,500 psig (10 to 103 BAR)
- 1** 300 to 3,000 psig (20 to 206 BAR)
- 2** 600 to 6,000 psig (40 to 414 BAR)
- 3** 1,000 to 10,000 psig (69 to 690 BAR)
- 4** 40 to 400 psig (2.7 to 28 BAR)

### BODY MATERIAL

- B** Brass
- T** 303 stainless steel
- U** 316 stainless steel

### OPTIONS

- N** 316 stainless steel panel nut

### SEAT MATERIALS

- 0** Ethylene propylene
- 1** Neoprene
- 3** Viton®
- 4** Buna N

### INLET & OUTLET PORTS

- 1** ¼" NPT female
- 2** ½" NPT female
- 3** ½" tube (MS33649-8)
- 4** ½" British parallel pipe  
 (vent pipe: ¼" BSPP)  
 (gauge ports: ¼" BSP)

Please consult your Circle Seal Controls distributor, representative, or the factory for information on special connections, operating pressures and temperature ranges.

## For Your Safety

It is solely the responsibility of the system designer and user to select products suitable for their specific application requirements and to ensure proper installation, operation, and maintenance of these products. Material compatibility, product ratings and application details should be considered in the selection. Improper selection or use of products described herein can cause personal injury or property damage.