

D9400 Series

0–3000 psig Miniature Pneumatically Actuated Valves



Features

- Zero leakage
- Anodized aluminum “top works” is corrosion resistant
- Actuator (pilot) port rotates for easy installation and locks with jam nut
- Optional metering adjustment resets maximum flow
- Provides preset metering for normally closed valves
- Pipe and instrument tube fittings

Technical Data

Body Construction Materials	Brass or 316 stainless steel
Stem Material	316 stainless steel
Diaphragm housing	Anodized aluminum, color blue
Seal materials	Buna N, Neoprene, Teflon® or Viton®
Diaphragm Materials	Dacron®/Buna N
Operating Pressure	3000 psig (207 bar)
Proof Pressure	4500 psig (310 bar)
Burst Pressure	12,000 psig (828 bar)
Actuator Pressure	30 to 200 psig (2 to 14 bar)
Temperature Range	–100° F to +400° F (–73° C to +204° C) <i>Based on o-ring material, see “How to Order”.</i>
Connection Sizes	¼”

Note: Proper filtration is recommended to prevent damage to sealing surface.

How it Works

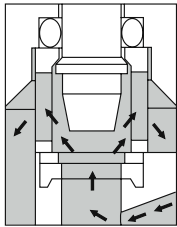

Full Open

Stem travel is stopped in the open position by metal-to-metal shoulders. O-ring surrounding the stem prevents external leakage. Actuator is completely removed from flow path to avoid contamination of the fluid or of the actuator

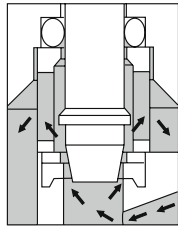

Opening to Metering Stop

No flow occurs during first portion of stem travel. Precise metering positions can be preset with the optional metering adjustment, thus positioning stem for the desired rate of flow.

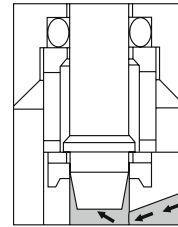

Close

Absolutely leakproof sealing is achieved by engaging precision machined stem into a captive seat. Seat cannot be damaged by back pressure. Shoulder on stainless steel stem seats on metal washer, which in turn is forced against resilient, non-galling seat to affect a dead-tight seal against the stem.

Circle Seal Controls

2301 Wardlow Circle • Corona, CA 92880
Phone (951) 270-6200 Fax (951) 270-6201
www.circle-seal.com

Shutoff valves

D9400 Series

Dimensions

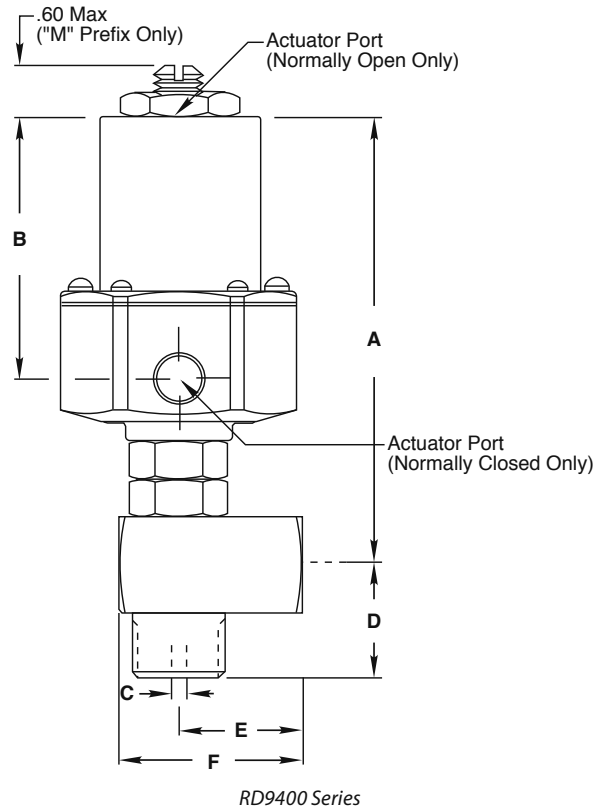
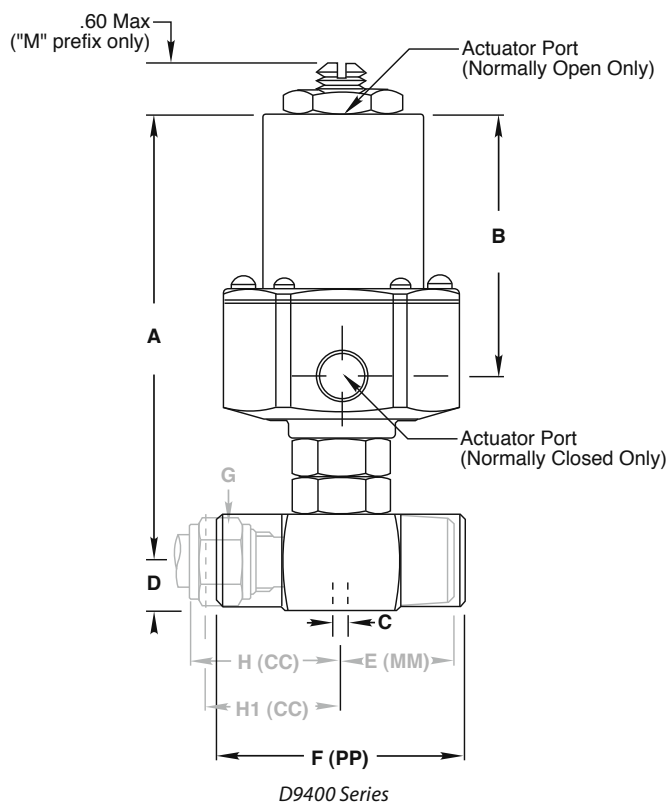

D9400 Series Dimensions (inches)

Dash No.	C Dia.	Cv	A	B	D	E (MM)	F (PP)	G Hex	H* (CC)	H1 (CC)	Actuator Port
4CC	.156	.32	3.504	1.891	.44	—	—	.562	1.04	.78	1/8" NPTF
2MM	.156	.32	3.462	1.891	.38	.84	—	—	—	—	1/8" NPTF
2PP	.156	.32	3.532	1.891	.44	—	1.86	—	—	—	1/8" NPTF

Body dimension (without nut and ferrule)

RD9400 Series Dimensions (inches)

Dash No.	C Dia.	Cv	A	B	D	E	F	Actuator Port
2MP	.156	.32	3.442	1.891	.875	.875	1.250	1/8" NPTF

D9400 Series

Flow Curve (Flow vs Lift)

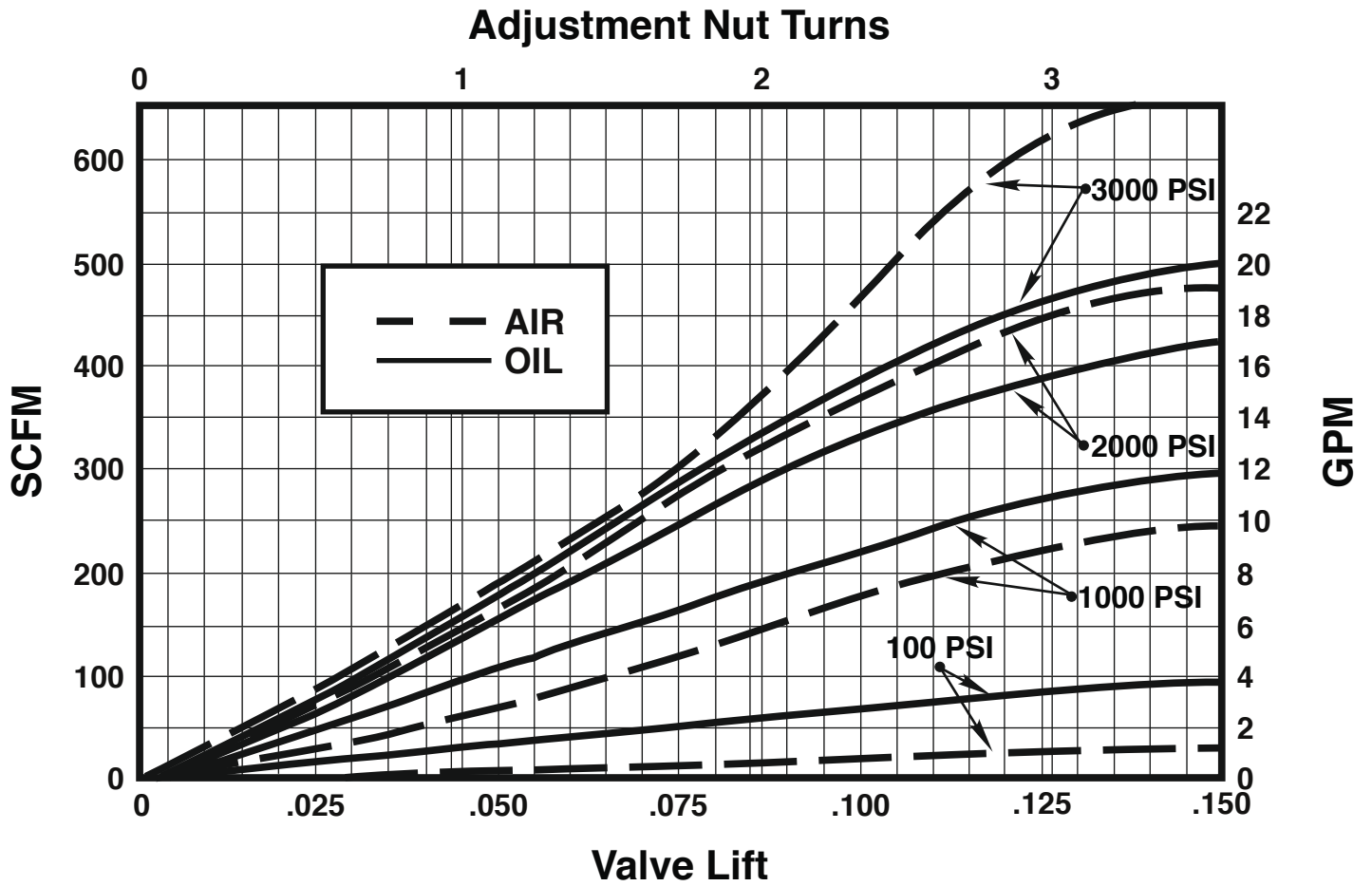

D9400 Series

How to Order

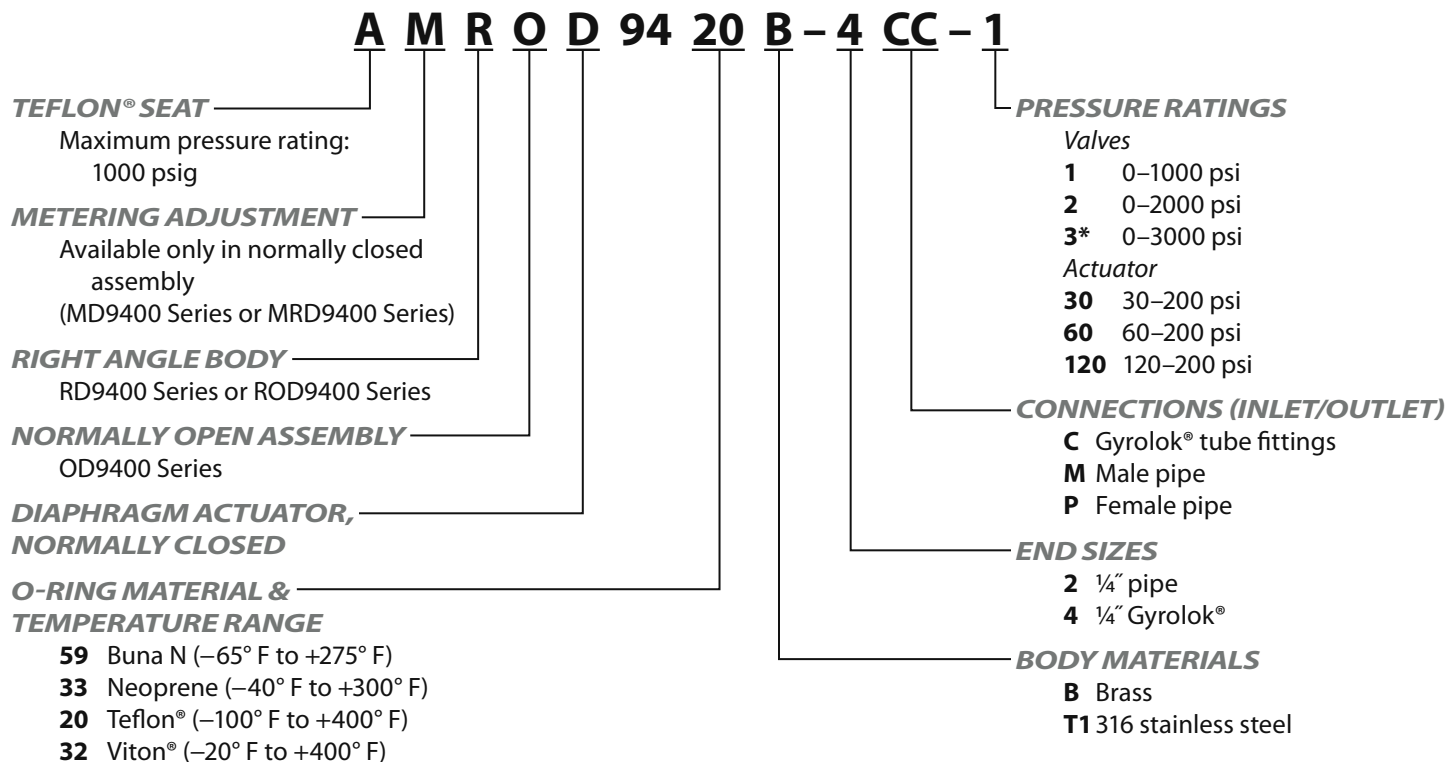

* Minimum operating temperature drop for the normally open –3 valve is 1000 psig.

Standard Seat Materials

Normally closed	0–1000 psi (Teflon®)
	0–3000 psi (Fluorogold®)
Normally open	0–1000 psi (Teflon®)
	0–3000 psi (Fluorogold®)

Please consult your Circle Seal Controls distributor or our factory for information on special connections, materials, larger sizes, o-rings, operating pressures and temperature ranges.

Repair Kits

In normal service, the only part(s) which may require replacement is(are) the seal(s). A repair kit may be ordered by placing a "K/" in front of the complete part number (i.e. K/D9420B–4CC–1).

For Your Safety

It is solely the responsibility of the system designer and user to select products suitable for their specific application requirements and to ensure proper installation, operation, and maintenance of these products. Material compatibility, product ratings and application details should be considered in the selection. Improper selection or use of products described herein can cause personal injury or property damage.

Gyrolok® is a registered trademark of HOKE Incorporated.

Dacron® is a registered trademark of E.I. du Pont de Nemours and Company.

Viton® is a registered trademark of DuPont Dow Elastomers.

Teflon® is a registered trademark of the DuPont Company.

Fluorogold® is a registered trademark of Fluorocarbon Company.