

SV Series

2- and 3-way Solenoid Valves for Gas and Liquid

SV10: Vacuum to 3000 psig

SV20: Vacuum to 6000 psig

SV30: Vacuum to 3000 psig

SV430: Vacuum to 3000 psig

SV460: Vacuum to 6000 psig



Features

- Zero Leakage
- Bi-directional flow
- Versatile: 3-way 2-position, 2-way normally closed, or 2-way normally open
- Balanced poppet design
- 303 stainless steel, brass or aluminum construction
- Minimum current required
- Rapid response
- Explosion-proof per MIL-STD-810B
- High pressure
- Direct acting
- Medium flow capacity

Technical Data

BODY CONSTRUCTION MATERIALS	303 stainless steel, brass or aluminum
SEAT MATERIALS	Nylatron®, polyimide (Vespel®), or PCTFE
PRESSURE RATINGS	SV10, SV30 & SV430: vacuum to 3000 psig (0 to 207 bar) SV20 & SV460: vacuum to 6000 psig (0 to 414 bar)
TEMPERATURE RANGE	-65° to +165° F (-54° to +74° C)
PORT SIZE AND CONNECTIONS	1/4", 3/8", 1/2" NPT or AND10050. MS33656 (SV10 only)
FLOW CAPACITY	SV10 & SV20: Cv=0.096, SV430: Cv=0.80 SV30: Cv=0.46, SV460: Cv=0.64

Circle Seal Controls

2301 Wardlow Circle • Corona, CA 92880
Phone (909) 270-6200 Fax (909) 270-6201
www.circle-seal.com

solenoid valves

SV Series

How it Works

3-way, 2-position, Normally Closed

Balanced Poppet Design The SV Series Solenoid Valves utilize a design that employs a single poppet, two pressurized sliding seals, and two main valve seats. The diameter of these seals and the two seats which the poppet seals against, have the same diameter. The pressure forces are always balanced regardless of poppet position. The only new force acting on the poppet is the poppet return spring or the forces exerted on the armature by the magnet coil.

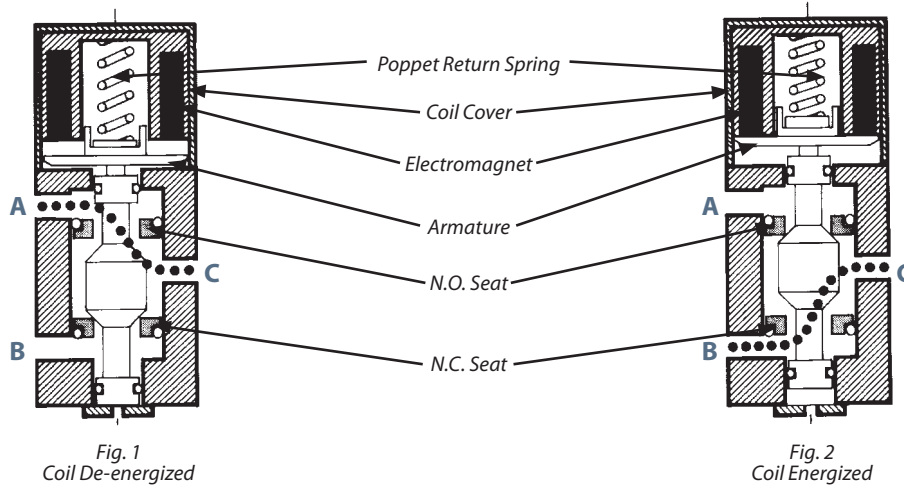

Fig. 1
Coil De-energized

Fig. 2
Coil Energized

The De-energized Position With the valve in a de-energized position and pressure applied to Port B, the valve operates as a 3-way, 2-position, normally closed valve. In this position a flow pattern from Port A to Port C is established (figure 1). Pressure can be applied to either port. The forces affecting the poppet are on the normally closed seat resulting from the poppet return spring.

Energized Position With pressure applied to Port B and electrical energy applied to the coil, the armature is drawn up against the coil compressing the armature return spring, and pulling the poppet up tight against the normally open seat of the valve, in this condition, a flow pattern between Port B and Port C is established and Port A is isolated (figure 2).

When the valve is de-energized, the poppet return spring forces the poppet to return to the normally closed seat and reestablishes a flow pattern between Port C and Port A with Port B being closed.

3-Way, 2-Position, Normally Open In this configuration pressure is applied to Port A rather than to Port B with the valve de-energized. Pressure is connected to Port C. When the valve is energized Port A is closed and Port C is connected to Port B.

2-Way, 2-Position Valves (Normally Closed or Normally Open) Any of the three ported valves may be converted to a two-way operation by plugging Port A or B. Plugging Port A provides a 2-way, 2-position, normally closed valve. Plugging Port B provides a 2-way, normally open valve. As shown in the "How to Order" section, Circle Seal Controls can also provide this valve as a 2-way, normally open or normally closed valve with only 2 ports as a standard item.

Selector Valve The 3-way, 2-position valves can also be used as selector valves by connecting two separate pressure sources to Ports A and B and then selectively running them to Port C depending on whether the valve is energized or de-energized. A single fluid source connected to Port C may also be diverted to Ports A or B selectively.

2- & 3-WAY SOLENOID VALVE SERIES	MAXIMUM PRESSURE PSIG	MAXIMUM FLOW	
		CV	ESEOD
SV10	3000	0.096	0.07
SV20*	6000	0.096	0.07
SV30	3000	0.46	0.16
SV430	3000	0.80	0.215
SV460	6000	0.64	.019

* 3-way, 2-position in SV20 Series is limited to 5000 psig (345 barg)

SV Series

Dimensions (Inches): SV10–SV30 Series

VALVE SIZE	A	A1	A2	B	C	C1	D	E	F	G	H	J	K	L	M
SV10–17	5.24	5.79	6.75	1.00	1.62	1.62	1.07	0.45	0.90	0.62	0.94	—	—	0.45	0.173 (2 holes)
SV20–27	5.97	6.52	7.46	1.00	2.00	2.00	1.04	0.46	0.95	0.46	0.92	0.92	0.95	0.46	0.218 (3 holes)
SV30–37	6.95	7.50	8.45 (DC Valves)	1.31	2.00	2.00	1.70	0.62	1.26	0.75	1.22	1.38	1.25	0.60	0.280 (3 holes)
			8.80 (AC Valves)		1/2" ports	2.25									

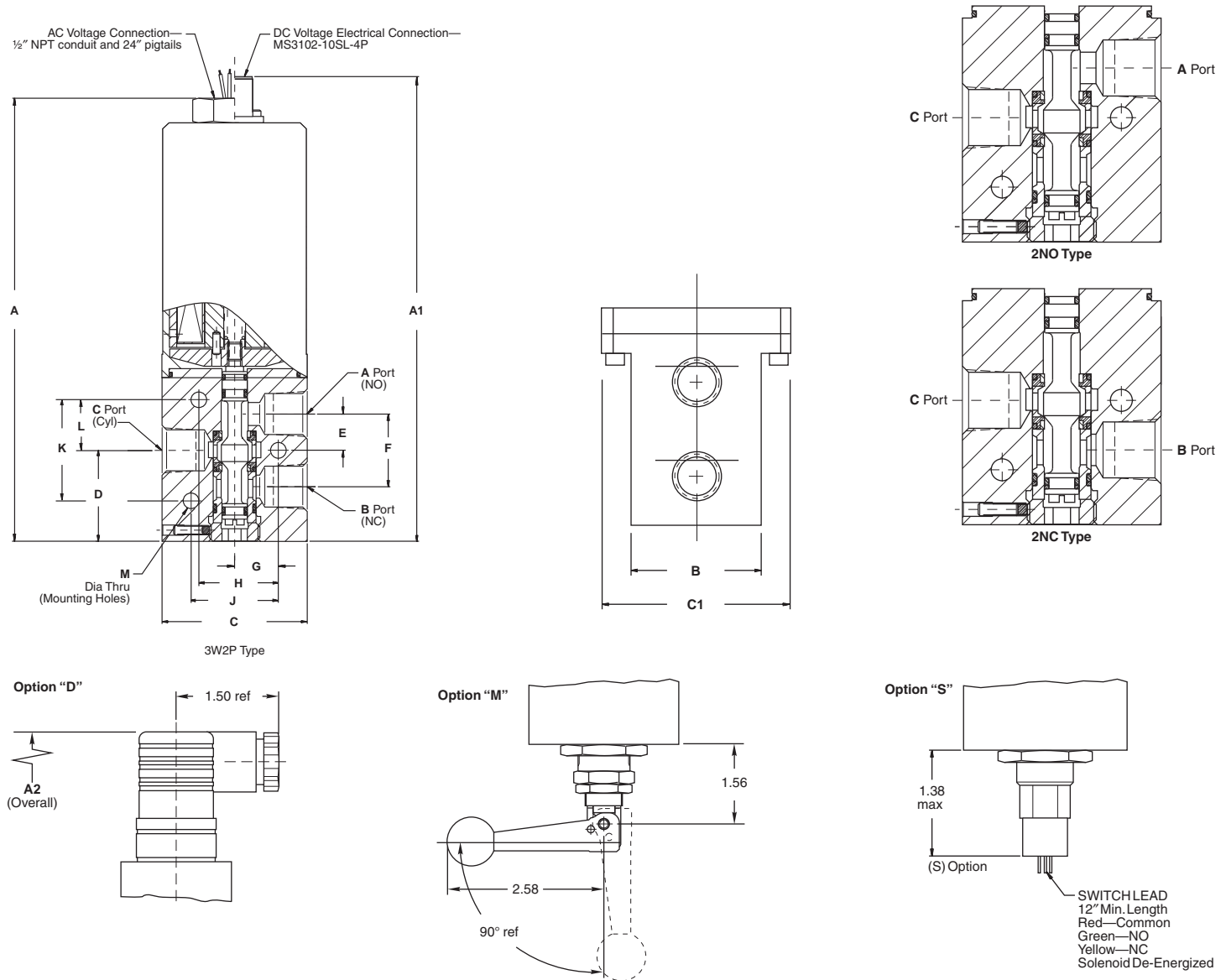

Basic Specifications: SV10–SV30 Series

PROOF PRESSURE	SV10 & SV30 Series: 6000 psig SV20 Series: 12,000 psig
TEMPERATURE RANGE	–65° F to +165° F (–54° C to +74° C)
LEAKAGE INTERNAL/EXTERNAL	Bubble-tight
FLUID MEDIA	Gases: air, nitrogen, oxygen, helium (stainless steel only) Liquids: lubricants, water, hydraulic fluids, hydrocarbon fuels
FLOW CAPACITY	SV10 & SV20 Series: Cv = 0.096 (Equivalent Sharp Edge Orifice Diameter (ESEOD) = 0.074") SV30 Series: Cv = 0.46 (Equivalent Sharp Edge Orifice Diameter (ESEOD) = 0.16")
TRIM	300 series stainless steel
DUTY	Continuous
WEIGHT (APPROXIMATELY)	Aluminum: SV10 = 1.5 lbs; SV20 = 2.3 lbs; SV30 = 2.6 lbs Stainless steel: SV10 = 2.0 lbs; SV20 = 3.0 lbs; SV30 = 3.8 lbs

SV Series

How to Order: SV10–SV30 Series

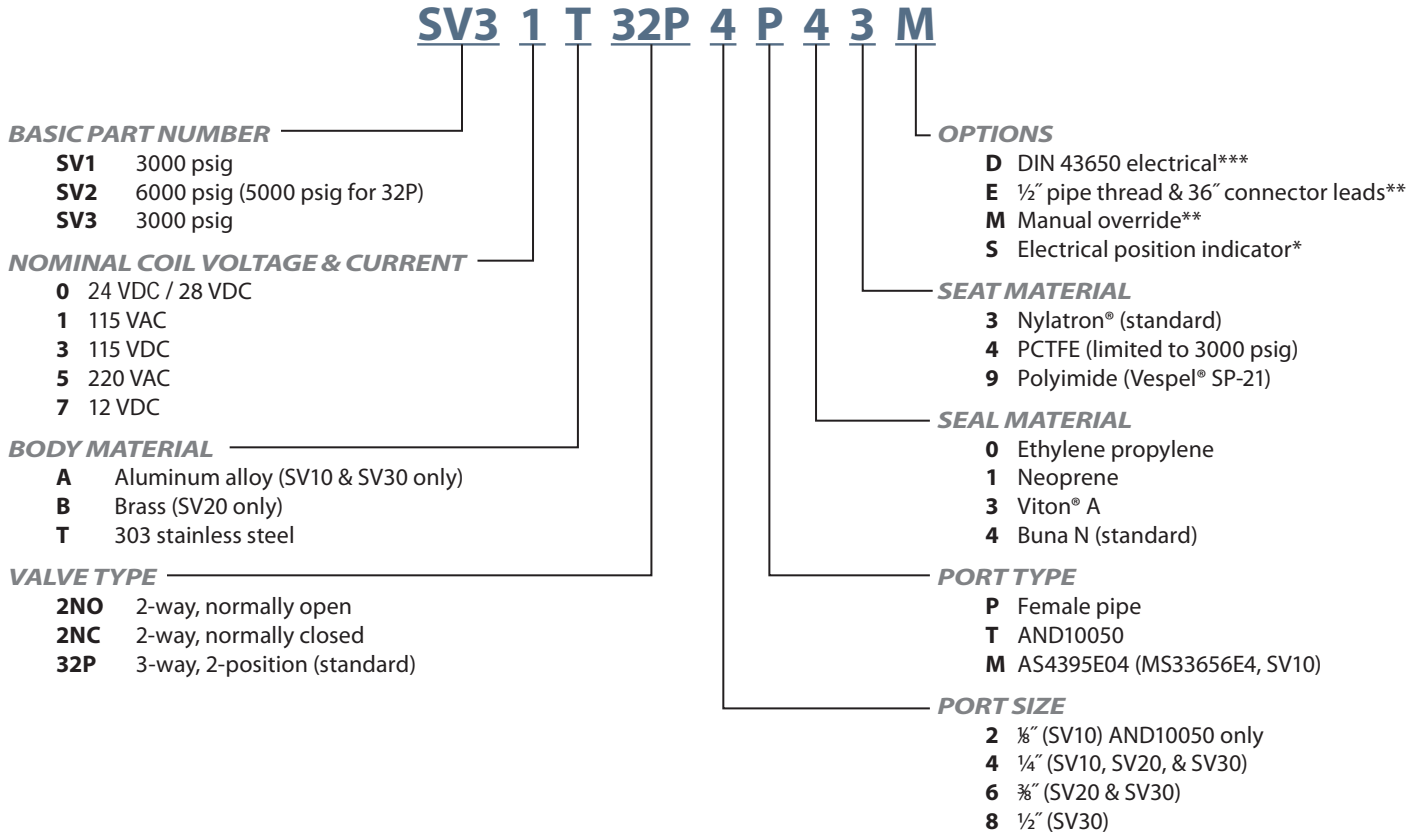

* Manual override and electrical position indicator are not available on the same valve.

** DC valves have MS3102-10SL-4P electrical connector. AC valves have 36" pigtails and 1/2" conduit.

*** DIN connector furnished complete.

Please consult your Circle Seal Controls distributor or our factory for information on special connections, materials, larger sizes, o-rings, operating pressures and temperature ranges.

Repair Kits

In normal service, the only part(s) which may require replacement is(are) the seal(s). A repair kit may be ordered by placing a "K/" in front of the complete part number (i.e. K/SV30T32P4P43).

SV Series

Dimensions (Inches): SV400 Series

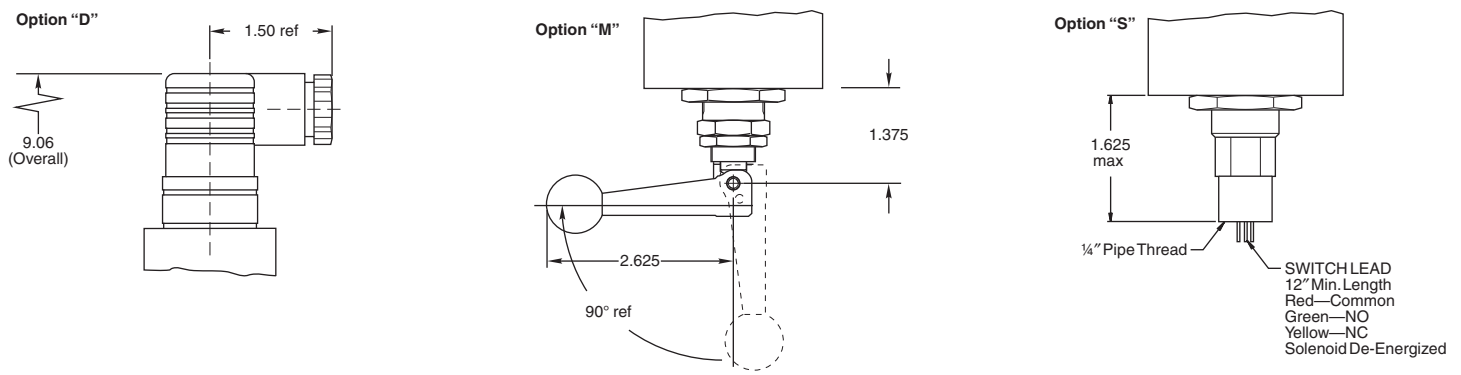
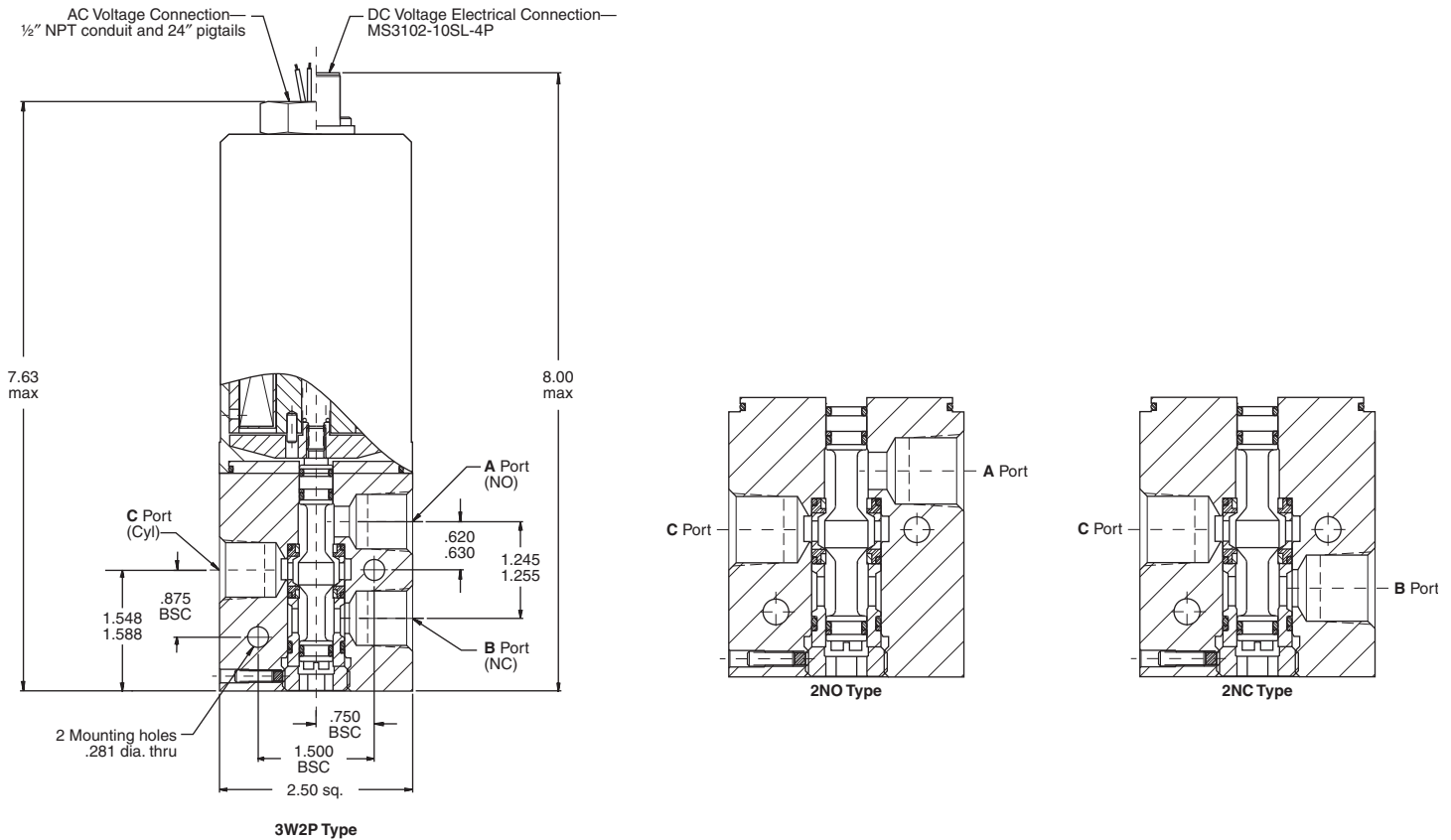

Basic Specifications: SV400 Series

PROOF PRESSURE	9000 psig
TEMPERATURE RANGE	-65° F to +160° F (-54° C to +71° C) 'C' option: -58° F to +165° F (-50° C to +74° C) (Fluid: +225° F/107° C max.)
LEAKAGE INTERNAL/EXTERNAL	Bubble-tight
FLUID MEDIA	Gases: air, nitrogen, oxygen, helium (stainless steel only) Liquids: lubricants, water, hydraulic fluids, hydrocarbon fuels
FLOW CAPACITY	SV43 Series: Cv = 0.86 (Equivalent Sharp Edge Orifice Diameter (ESEOD) = 0.215") SV46 Series: Cv = 0.64 (Equivalent Sharp Edge Orifice Diameter (ESEOD) = 0.190")
TRIM	300 series stainless steel
DUTY	Continuous
WEIGHT (APPROXIMATELY)	Aluminum: 5.2 lbs Stainless steel: 8.1 lbs

SV Series

How to Order: SV400 Series

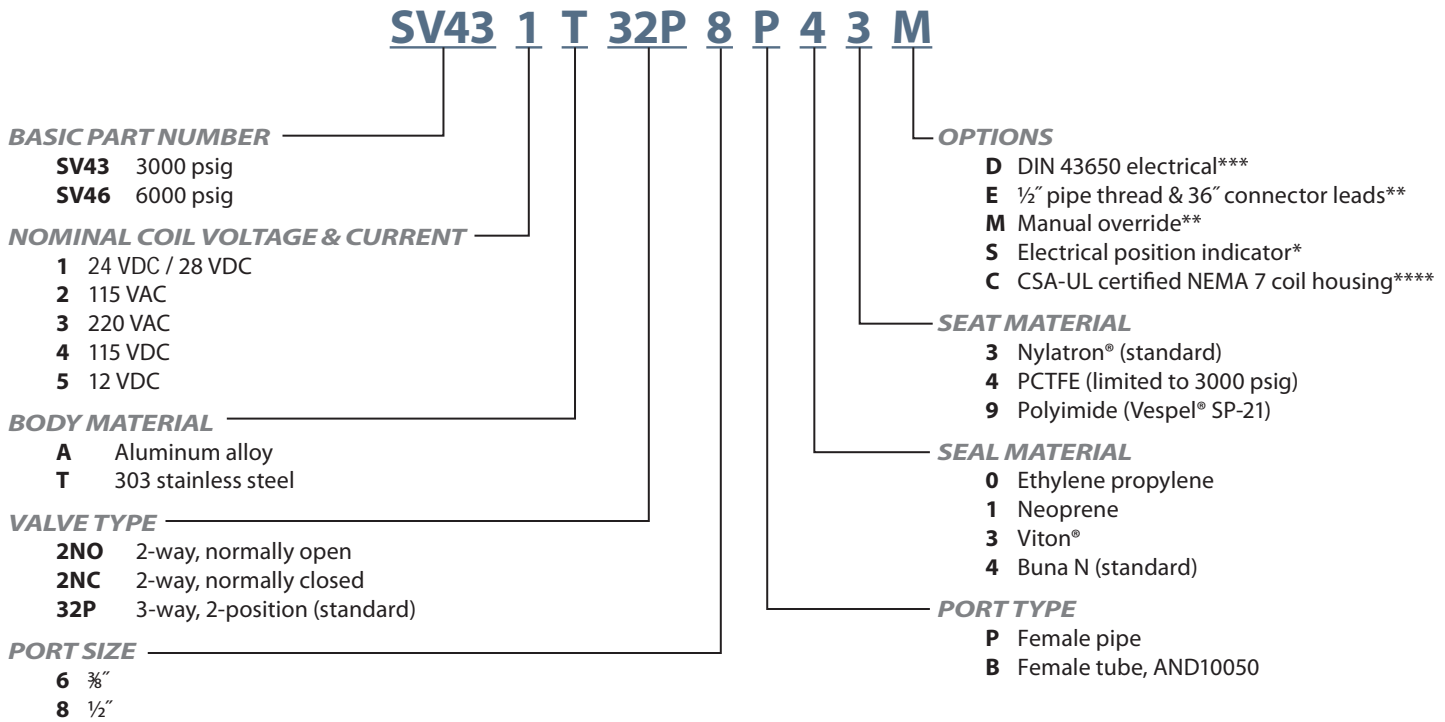

* Manual override and electrical position indicator are not available on the same valve.

** DC valves have MS3102-10SL-4P electrical connector. AC valves have 36" pigtails and 1/2" conduit.

*** DIN connector furnished complete.

**** The "C" option is only available with the following:

- 1/2" pipe thread and 36" connector leads (standard)
- Seat material: Nylatron® and PCTFE
- Seal Material: Buna and EPDM
- SV46 in aluminum has a maximum operating pressure of 4000 psig (276 barg)

Please consult your Circle Seal Controls distributor or our factory for information on special connections, materials, larger sizes, o-rings, operating pressures and temperature ranges.

Repair Kits

In normal service, the only part(s) which may require replacement is(are) the seal(s). A repair kit may be ordered by placing a "K/" in front of the complete part number (i.e. K/SV431T32P8P43M).

For Your Safety

It is solely the responsibility of the system designer and user to select products suitable for their specific application requirements and to ensure proper installation, operation, and maintenance of these products. Material compatibility, product ratings and application details should be considered in the selection. Improper selection or use of products described herein can cause personal injury or property damage.

Viton® is a registered trademark of DuPont Dow Elastomers.

VespeI® is a registered trademark of E.I. du Pont de Nemours and Company.

Nylatron® is a registered trademark of DSM Engineering Plastic Products.

